

Q-CATCH®

74 SERIES



 **ARROWQUIP**

WHY ARROWQUIP?

The 400 Series cattle chutes were created to provide practical ranchers with straightforward cattle handling solutions that do not compromise safety and quality for affordability. Unlike anything else in the market, Arrowquip's economical chute lineup gives ranchers the opportunity to step up their operation using equipment designed with precision engineering and animal science.

MODEL: DELUXE VET [7400]

WEIGHT: 1900 lbs.

DIMENSIONS: 58" w x 95" h x 130" l

MODEL: STANDARD [7400MR]

WEIGHT: 1680 lbs.

DIMENSIONS: 58" w x 95" h x 105" l

THE EASIEST WAY TO IMPROVE YOUR RANCH

The Q-Catch 74 Series cattle chute is the easiest way to boost your operation's efficiency. With quality features inspired by the world famous 600 Series cattle chutes, the Q-Catch 74 Series gives you practicality and efficient engineering combined. Complete with the same patented auto-locking mechanisms, full access points, and user-friendly features, this manual squeeze chute has earned its place in the Q-Catch family.

PRODUCT WARRANTY

- Manual cattle chute - **7 YEARS**
- Patented head gate friction locks – **LIFETIME**
- Patented squeeze friction locks – **LIFETIME**
- Rump fingers – **LIFETIME**

Products must be registered to claim warranty. Contact your Authorized Arrowquip Dealer for more information.

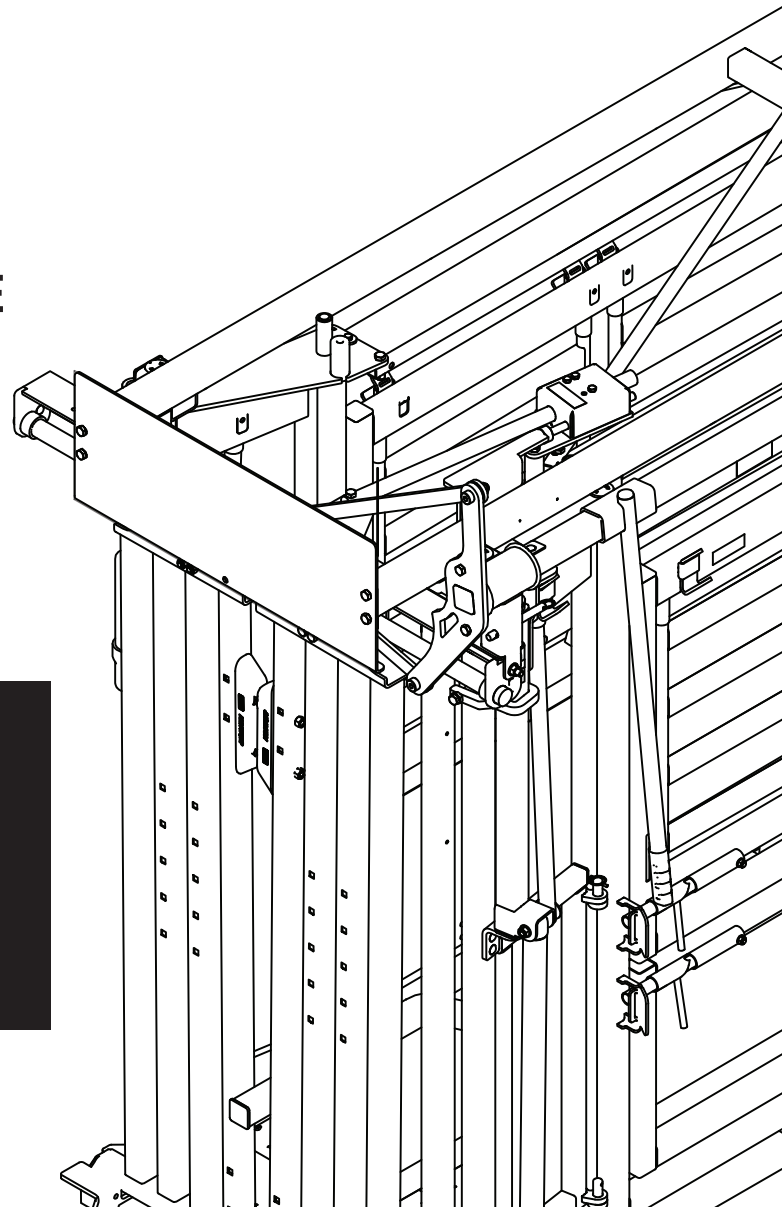



3E Q-CATCH HEAD GATE [PATENTED]

- Uses light to draw cattle into the chute
- **NEW** barred style allows cattle to see light past the head gate
- Patented locking mechanism features infinite adjustments
- Self-lubricating head gate rollers are maintenance-free
- Opens to a full 30" top to bottom
- Single lever push-to-close, pull-to-open operation never requires adjustments

HEAD GATE OPERATION HANDLE

- User-friendly handle that reduces operator's fatigue
- Handle can be situated anywhere along the side of the chute



NEW DIRECT DRIVE SYSTEM [PATENT-PENDING]

- Enhanced design provides a direct connection from the control tube to the head gate
 - Provides instant head gate response time
 - Head gate operation can be easily converted* to the opposite side
- *Requires additional parts. See product manual.

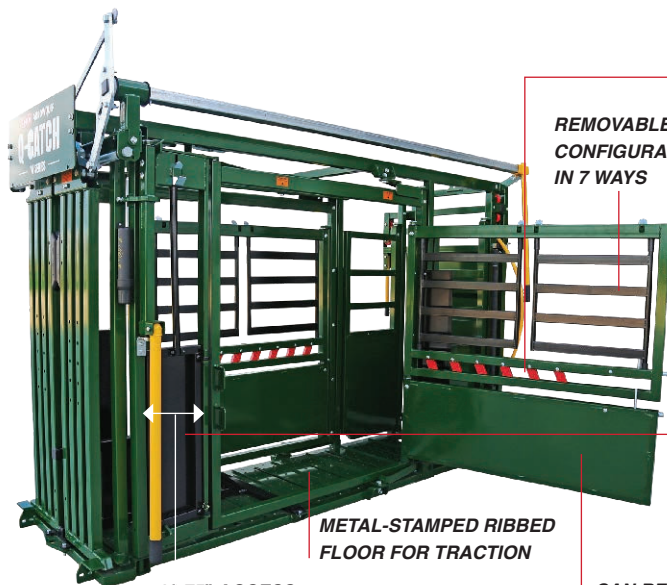

REMOVABLE AND CONFIGURABLE IN 7 WAYS

RUMP FINGERS

- Nylon rump fingers designed to endure high pressure
- Includes a heavy-duty rubber-coated fiberglass rump bar that is light and slip-resistant

NEEDLE ACCESS [PATENT-PENDING]

- **NEW** drop-down needle bar allows for quick access to the neck
- Completely removable panel

FLOORING [PATENT-PENDING]

- Made with industry-grade American steel
- Designed with slots for drainage and easy cleaning
- Secured with stainless steel structural rivets used in aircrafts

METAL-STAMPED RIBBED FLOOR FOR TRACTION

12.75" ACCESS TOP TO BOTTOM

CAN BE USED INDEPENDENTLY OR TOGETHER

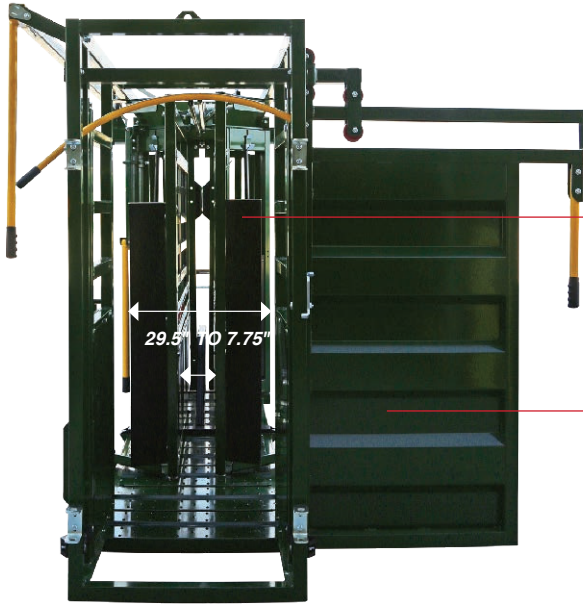

SQUEEZE

- Single lever push-pull operation
- Designed to work with cattle of any size
- Patented squeeze mechanism never requires adjustments

ROLLING TAIL GATE

- Reversible offside & onside operation
- Top-mounted to eliminate the issue of build-up



PORTABILITY

- Transport-ready with the NEW wheel kit add-on
- NEW 3" x 3" beams provide a durable structure for transportation



MOUNT BRACKETS

- Allows you to place the chute on load bars for weighing cattle
- Can be used to secure the chute to the ground with bolts

VET DOOR

- Improved slam latch ensures the door won't swing through when slammed shut

SWINGS 180° IN & OUT

ADD-ONS



NEW WHEEL KIT

You can easily transport your cattle chute to another site with the new wheel kit. The wheel kit comes with two manual jacks, an adjustable hitch, a jack adaptor for the hitch, and two 14" tires.



NEW STERNUM BAR

The sternum bar prevents cattle from going down in the chute. The improved design is sheeted to prevent hoof traps, and is easily installed or removed with 2 bolts.



NEW CHIN BAR

The chin bar is a simple add-on that raises the chin when access to the head is needed.



NEW TRIMMING BAR

The trimming bar provides added safety when clipping cattle. You can adjust the position and angle of the bar along the side of the chute to suit your needs.



NEW 3RD GENERATION HEAD HOLDER [PATENTED]

The head holder is a sturdy mechanism that clamps around the animal's neck and holds the head immobile. The head holder features single-lever push pull operation, and simplifies any procedure requiring access to the animal's head. The **NEW** 3rd generation head holder is more heavy-duty than previous models, and features new mechanical connections.

Arrowquip was founded in 1988 by the Firth family in Australia with the mission "To influence the livestock handling industry globally through the practical application of animal science and welfare standards, and increase producer safety and profitability with innovative equipment". This inspiration came while working cattle on their family ranch in Australia, due to the challenges they encountered with the lack of quality livestock handling solutions available to ranchers. As a forward-thinking family, they began to develop solutions to fill this gap in the market, and have been providing the high-quality livestock handling equipment producers are seeking ever since.

Arrowquip is the only manufacturer to employ a full-time team of engineers dedicated specifically to cattle handling in our industry. Every

piece of equipment we develop undergoes an extensive development period in which our R&D Team exhausts every possible avenue to make our equipment the best it can be for the handler to work their livestock. As a result, our equipment is recognized worldwide as the most innovative and thoughtfully designed livestock equipment in the market today.

In the last 30 years, Arrowquip has become a world-renowned manufacturer of cattle handling solutions known for their innovative designs, technological advancements, investment in animal science, and forward-thinking equipment. Our years of research, equipment development process, extensive testing periods, and the refusal to settle for "good enough" have set a new precedent within the livestock handling industry.

