



ARROWQUIP

PRODUCT MANUAL

Q-CATCH[®]

CATTLE CHUTES

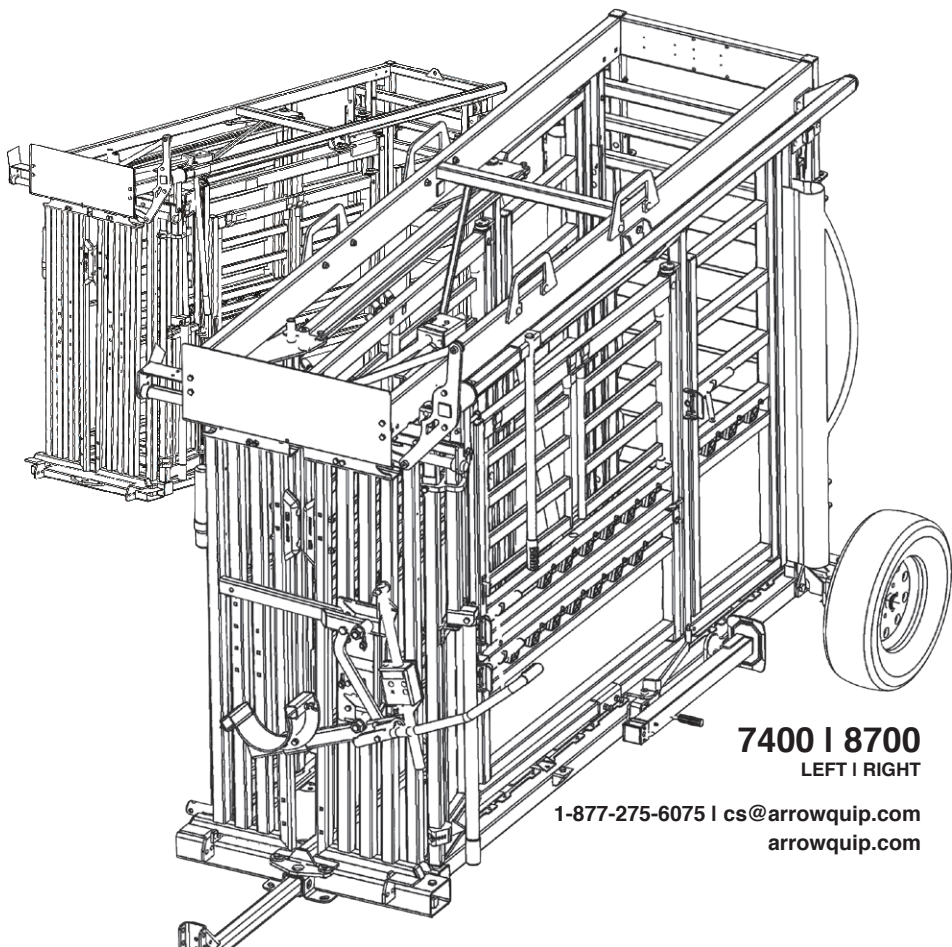

7400 | 8700

LEFT | RIGHT

1-877-275-6075 | cs@arrowquip.com

arrowquip.com

THIS PRODUCT MANUAL IS FOR THE FOLLOWING PRODUCTS:

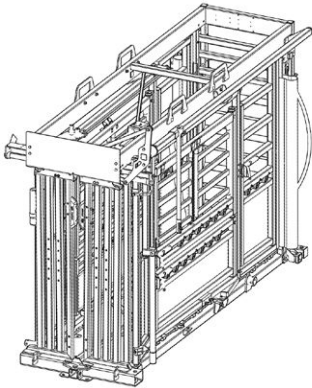

Q-Catch 87 Series Deluxe Vet

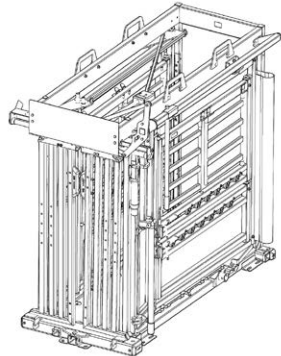

Q-Catch 87 Series Standard

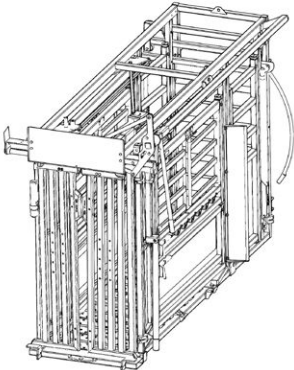

Q-Catch 74 Series Deluxe Vet

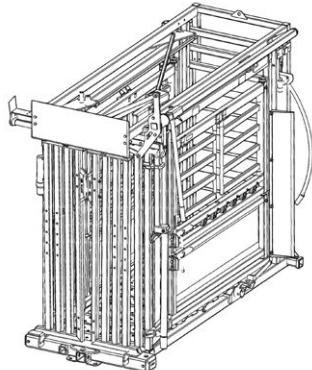

Q-Catch 74 Series Standard

CONTENTS

Safety Precautions	1
Risk Assessment	2
Operating the Q-Catch® Cattle Chute	2
3E Q-Catch Head Gate Assembly	3
Emergency Head Gate Release	3
Head Gate & Squeeze Conversion	5
Rolling Door Switch	17
Recommended Maintenance	20
Regular Maintenance (Every 6 Months)	20
When Necessary	22
Troubleshooting Guide	23
Recommended Use	24
Warranty	24
Add-Ons Maintenance & Safety Precautions	24
Manual Head Restraint: 3rd Generation Head Holder / Chin Bar	24
Sheeted Sternum Bar	26
Trimming Bar	27
Wheel Kit	28
Installation	29
Removal	33
Wheel Maintenance	36

PLEASE FOLLOW ALL SAFETY INSTRUCTIONS PROVIDED IN THIS MANUAL BEFORE OPERATION. ARROWQUIP DOES NOT ACCEPT RESPONSIBILITY FOR ANY ACCIDENTS OR INJURY WHEN THIS SAFETY MANUAL HAS NOT BEEN READ IN FULL AND KEPT WITH THE PRODUCT AT ALL TIMES. OPERATORS OF THIS PRODUCT TAKE AND ACCEPT RESPONSIBILITY FOR ANY HARM OR INJURY TO THE ANIMAL OR OPERATOR WHEN IT PERTAINS TO HOW THE EQUIPMENT IS USED AND MAINTAINED.

Please keep this manual for frequent reference and to pass on to new users or owners.

SAFETY PRECAUTIONS

PLEASE FOLLOW ALL SAFETY PRECAUTIONS OUTLINED HEREIN. ANY HARM TO THE ANIMAL OR INJURY TO THE OPERATOR WHICH OCCURS DUE TO HOW THE PRODUCT IS OPERATED, OR RESULTING FROM A LACK OF SAFETY PRECAUTIONS ARE THE SOLE RESPONSIBILITY OF THE OPERATOR.

All farm machinery and equipment are potentially dangerous. Careless use of any Arrowquip livestock equipment may cause injury or damage to persons, cattle, or property. Arrowquip has taken precautions in the design and manufacturing of this product to ensure that it is safe and user-friendly. Therefore, the user must assume all responsibility and risk associated with the possession and use of the cattle squeeze chute.



WARNING: READ BELOW BEFORE OPERATION.

Ensure the operator understands the contents of this manual before using the cattle squeeze chute.

1. **DO NOT** wear loose-fitted clothing.
2. Ensure the cattle squeeze chute is on a firm, level, dry surface that is free of rocks and other trip hazards. A level concrete pad flush with the ground and with the chute bolted to the concrete is strongly recommended.
3. **DO NOT** enter the vet cage until the animal is secured in the head gate and the rump bar has been placed so that the cow cannot back up.
4. **DO NOT** stand in front of the head gate while operator is moving the cattle through the squeeze chute.
5. **DO NOT ALLOW CHILDREN UNDER THE AGE OF 18 NEAR AN OPERATING MACHINE.**

6. Follow safe cattle handling procedures in other areas of the yard so that cattle are more docile in the chute.
7. **DO NOT** make any modifications to Arrowquip equipment. Non-factory modifications to the equipment can reduce the safety for the operator & livestock, and void warranty.

RISK ASSESSMENT

Conduct a risk assessment on procedures for which the cattle squeeze chute used and establish a safe work procedure.

1. Ensure all users of the equipment have been inducted and comply with safe working procedure.
2. Please ensure that there are NO large or hazardous objects inside the chute that may cause injury to the animal or operator, or may cause the equipment to malfunction.
3. Make sure that your chute has been cleared of ALL livestock after use.
4. Some chemicals and medicines can damage powder coat. Take all precautions and wash after use.

OPERATING THE Q-CATCH CATTLE CHUTE



ENSURE ALL CHUTE FUNCTIONS AND ADD-ONS ARE WORKING PROPERLY BEFORE OPERATING.

1. Ensure the head gate, tail gate, and all access points are closed before the animal enters the chute.
2. Open tail gate for the animal to enter the squeeze chute enclosure.
3. Close tail gate.
4. Open head gate slightly more than the neck size of the animal to tempt the animal to stick its head through the head gate. When neck of animal is in the correct position, quickly close the head gate securely on the animal's neck.
5. If required, side squeeze animal and engage head restraint to restrain further movement.
6. If the animal applies excessive pulling pressure on head gate, it is recommended to use the anti-backing bar behind cattle rump.



CONFIRM ANIMAL IS SECURELY HELD BEFORE CARRYING OUT ANY HUSBANDRY WORK.

3E Q-CATCH HEAD GATE ASSEMBLY

Your chute will come with the head gate fully assembled and ready for use. However, if you need to disassemble your head gate for any reason, the following guide will help you to properly reassemble your chute.

ASSEMBLING THE Q-CATCH HEAD GATE

Fit the mechanism parts as shown in the diagram below.

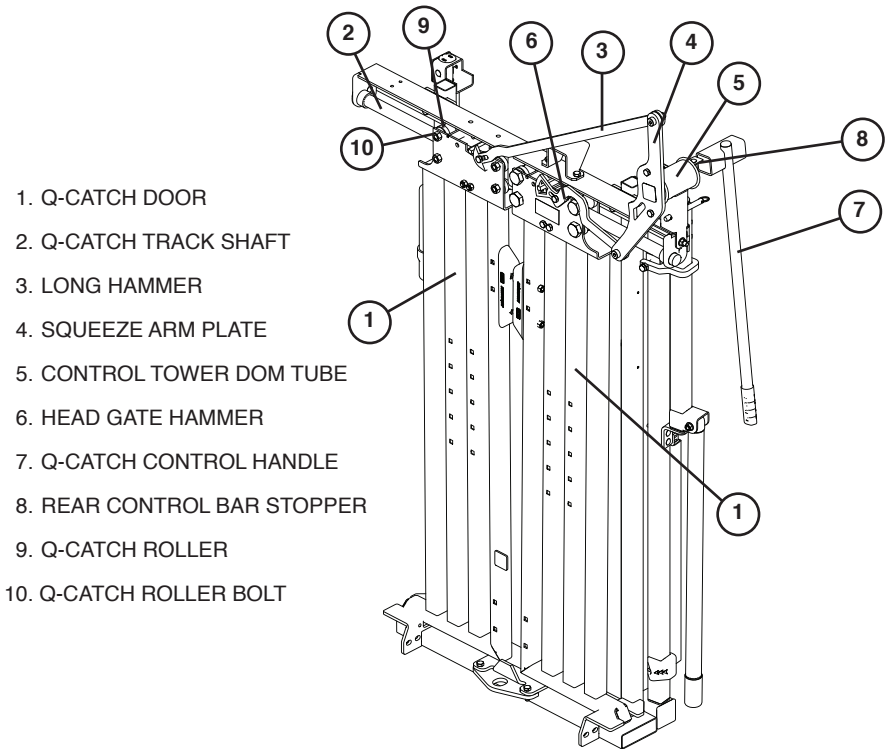

EMERGENCY HEAD GATE RELEASE

Arrowquip squeeze chutes are designed to ensure the safety of both animal and operator. **With proper maintenance and lubrication, the head gate will not jam under pressure.** However, in the rare event that an animal becomes stuck in the head gate, the following guidelines will ensure you are able to release your animal quickly and safely.

Required Tools:

- Screw Driver/Pry Bar

STEPS TO RELEASE LOCK

- 1** Go to the offside of the chute, to ensure you will not be hit by the head gate handle. If your chute is designed for offside operation, you will need to go to the nearside of the chute.
- 2** Place screwdriver/pry bar under bottom head gate roller on the outer edge of the door. (This is the side with the "L" curve, not the straight side.) Insert screwdriver/pry bar into the small space above the spring in the head gate lock plate.

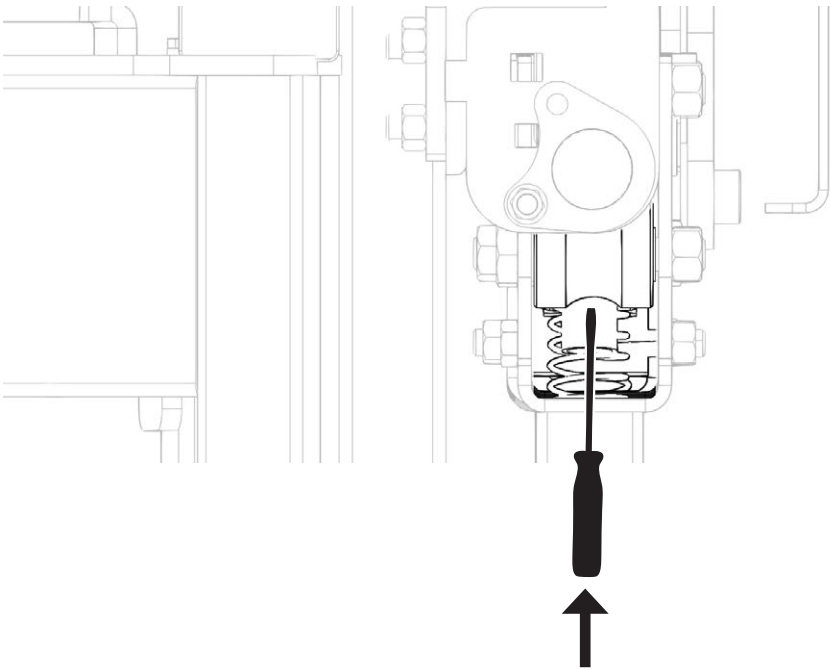
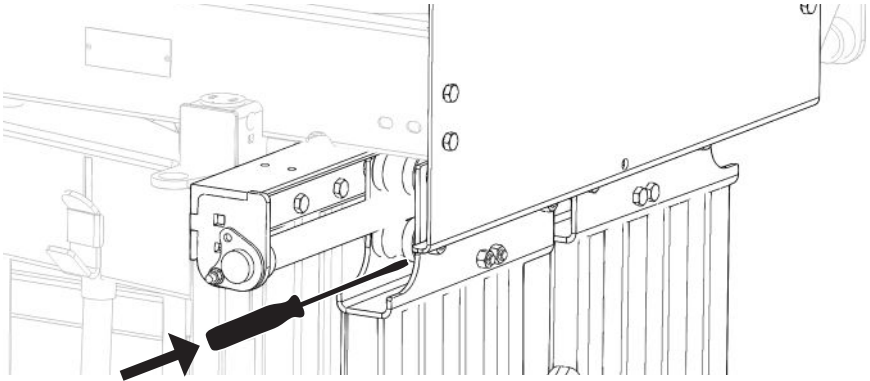

- 3** Tilt the screwdriver/pry bar up and into the head gate roller. This will push down the spring, releasing the locking mechanism on the head gate door.

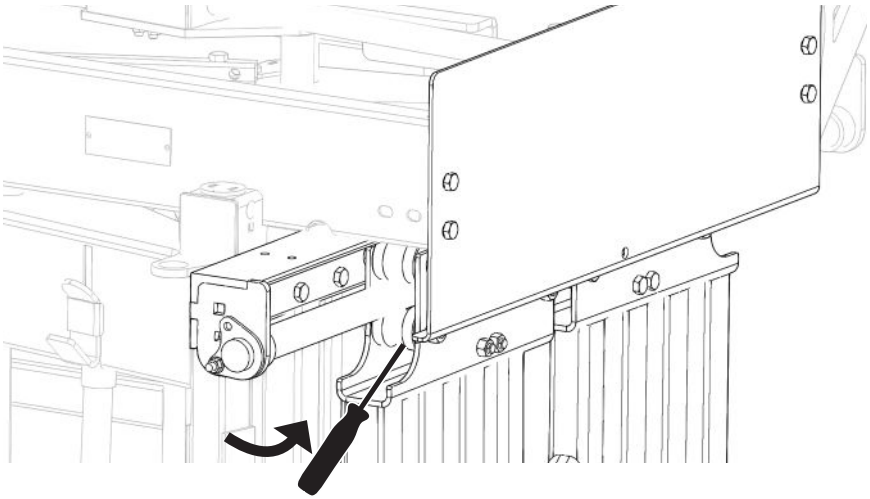

HEAD GATE & SQUEEZE CONVERSION

Arrowquip squeeze chutes can be ordered based on your preferred operating side. In the rare event that you would need to operate the head gate and squeeze on the opposite side, please contact your local dealer for additional parts and follow these instructions.

ADDITIONAL PARTS TO ORDER

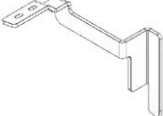
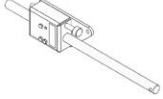
	Left-Hand Product Code	Right-Hand Product Code
<p>Squeeze Fandangle</p> 	2003192	2003716
<p>Squeeze Lockbox</p> 	2000355	2002384

Required Tools

- 9/16" wrench
- 3/4" wrench
- 15/16" wrench
- 3/8" hex key

LEFT-HAND TO RIGHT-HAND

NOTE: Switching from Left-hand to Right-hand operation shown. For Right-hand to Left-hand operation, complete the steps from the opposite side.

**** REMINDER ****

SET PARTS ASIDE TOGETHER WITH THE CORRESPONDING BOLTS AND WASHERS.

1 Remove the Q-Catch shield.

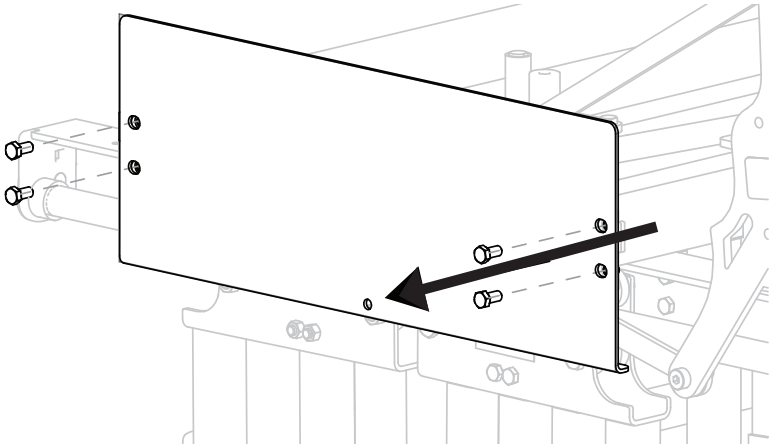

2 Remove the head gate hammer and squeeze arm plate.

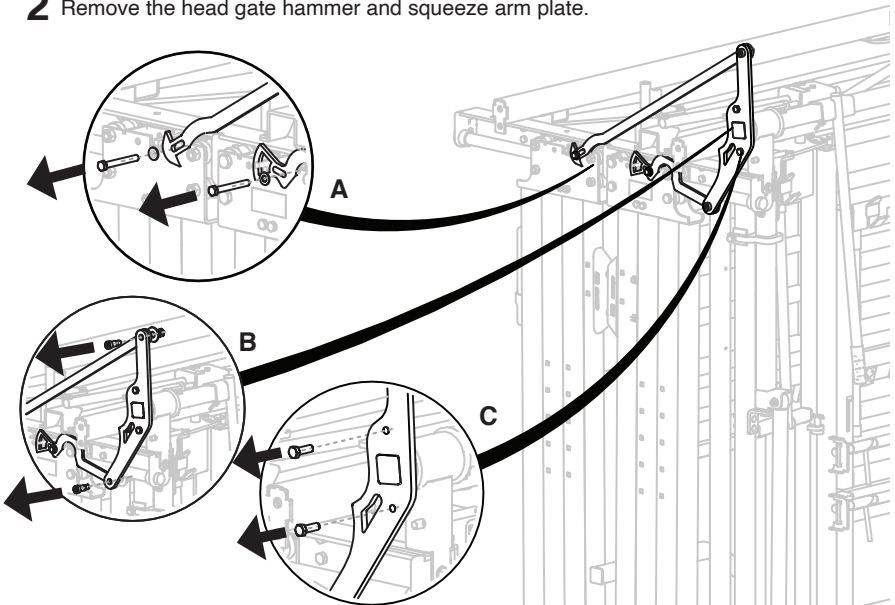

3 Remove the control tube and Q-Catch handle.

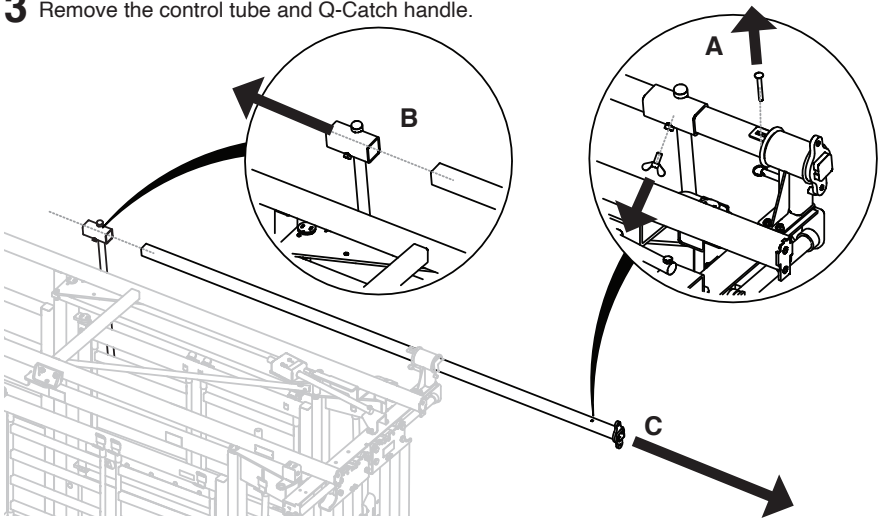

4 Detach the control tower vertical tube.

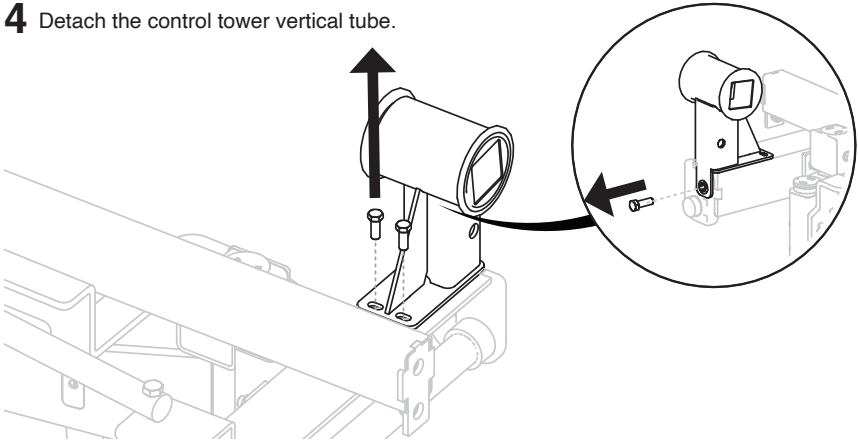

5 Unbolt the shaft, rotate to align with the second hole, and secure.

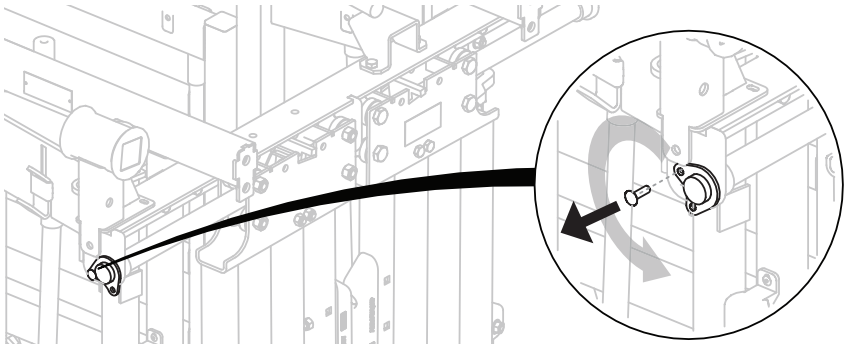

6 Install the control tower vertical tube and fasten with bolts.

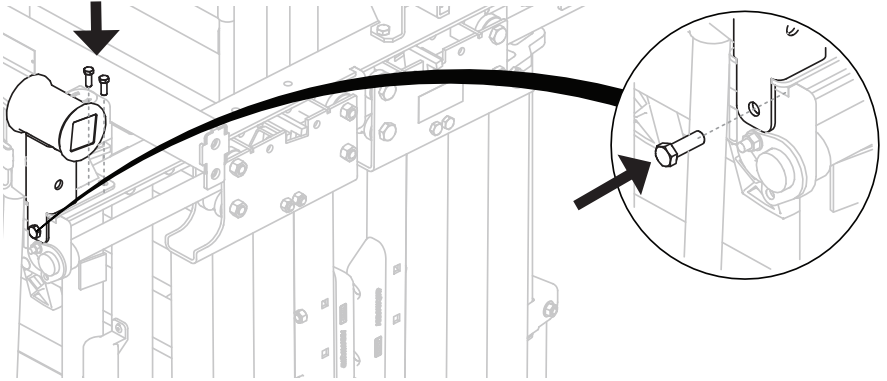

7 Flip the axle pin on the rear control bracket and transfer it to the opposite side.

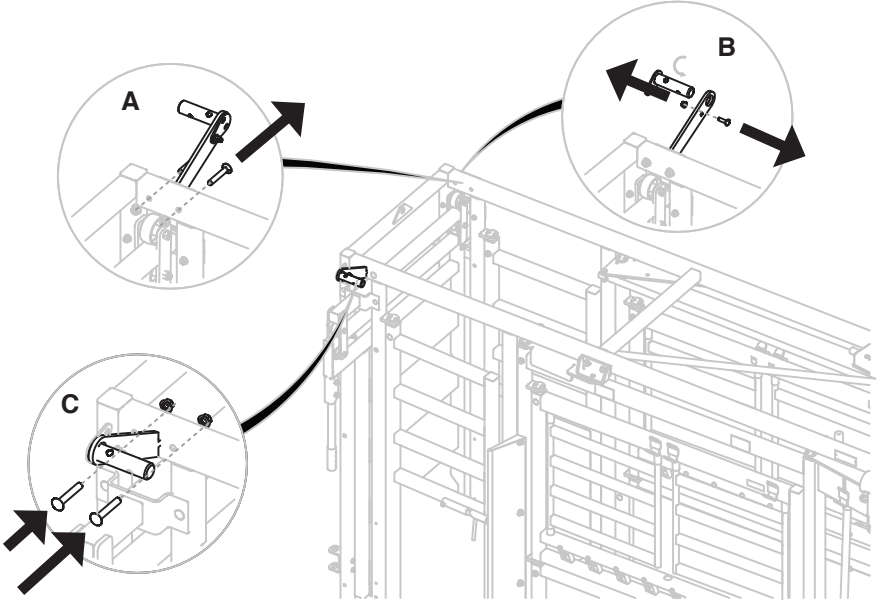

8 Feed the control tube through the control tower vertical tube.

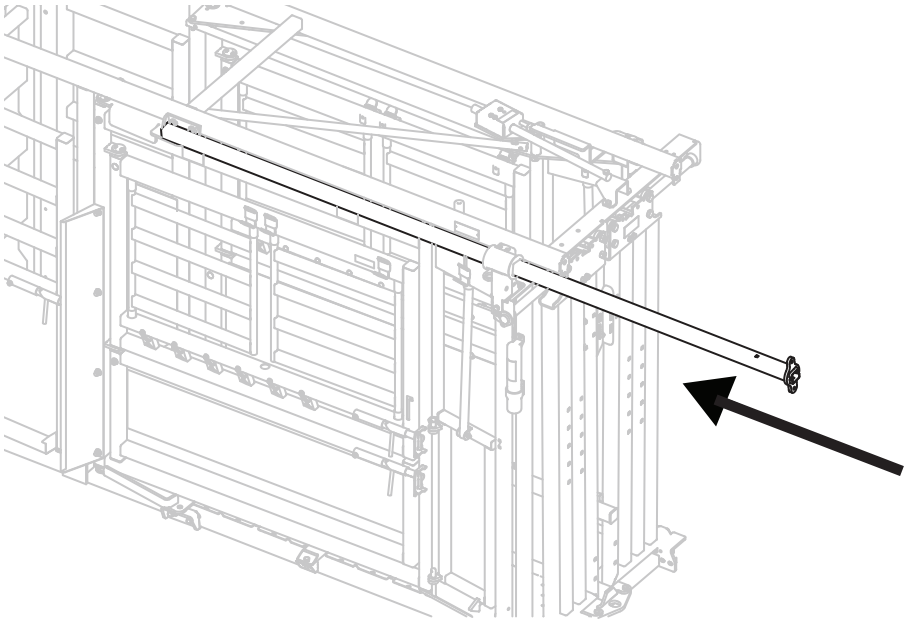

9 Insert the Q-Catch handle and mount the control tube on the rear control bracket. Secure with a bolt on the opposite side.

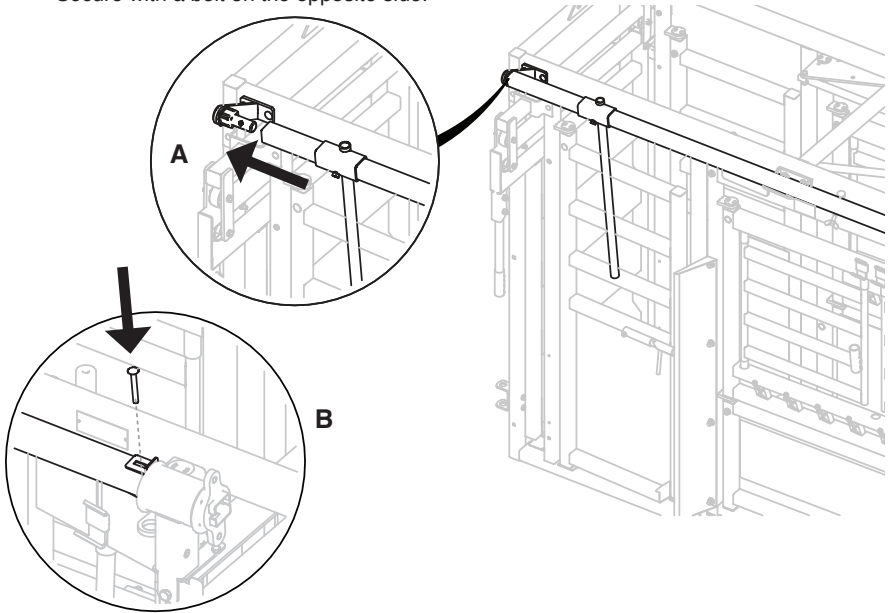

10 Install the squeeze arm plate.

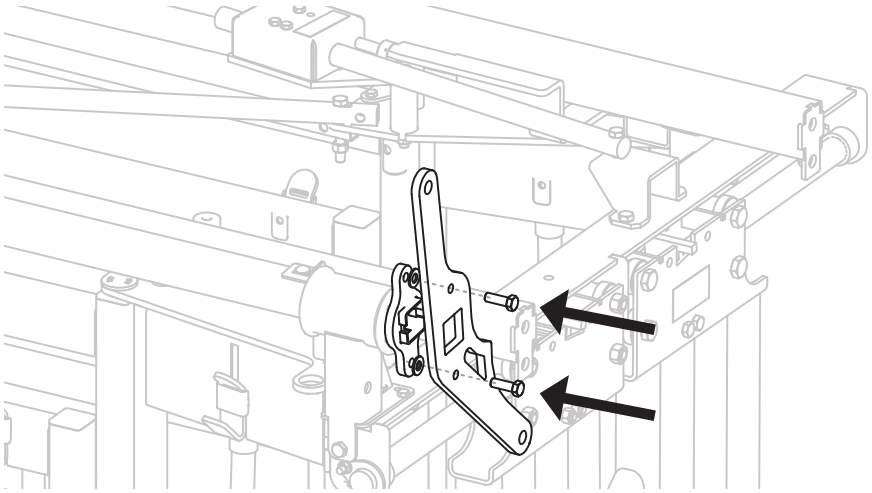

11 Install the head gate hammer and connect it to the squeeze arm plate.

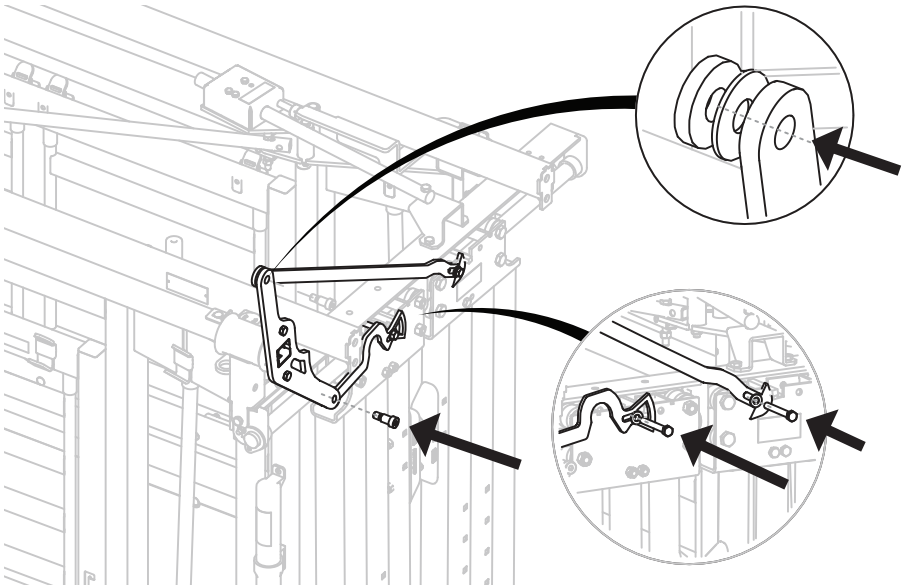

12 Install the Q-Catch shield.

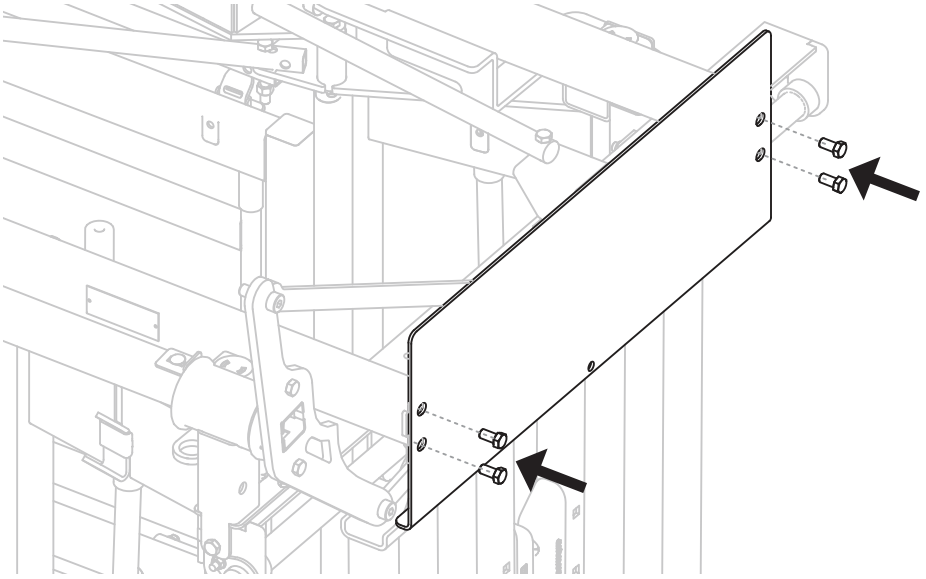

STOP SQUEEZE THE CHUTE TO REMOVE THE FANDANGLE.

13 Remove the Left-hand fandangle and squeeze bracket.

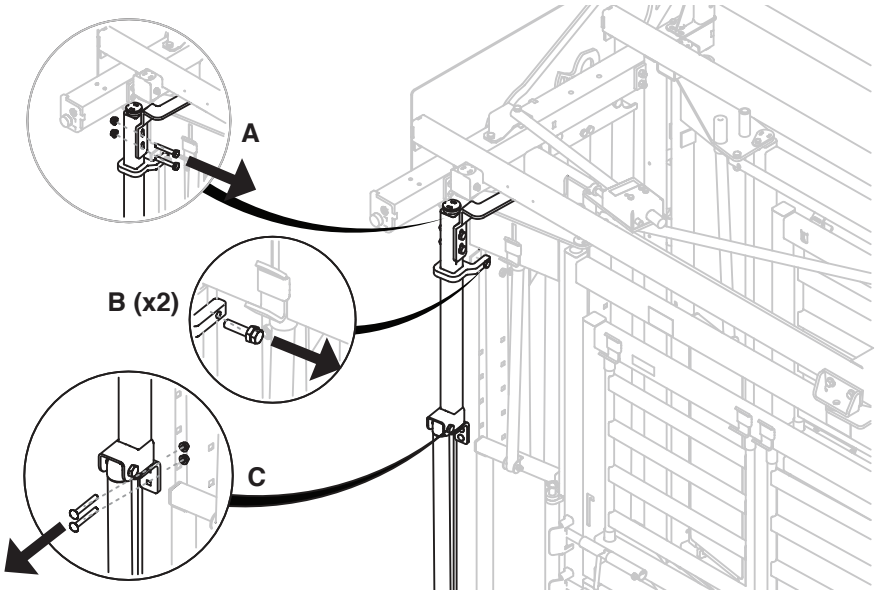

14 Install the squeeze bracket and Right-hand fandangle on the opposite side.

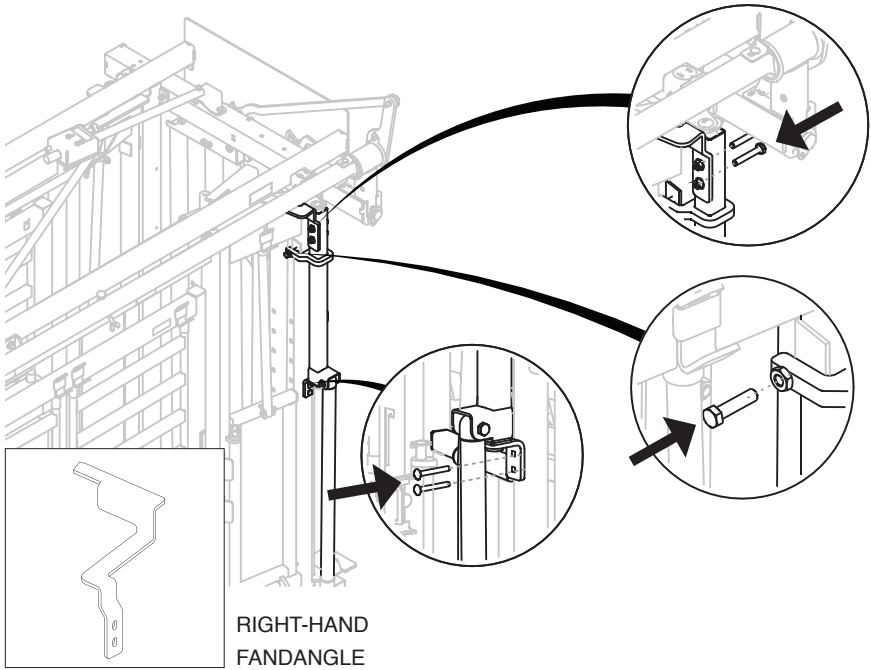

STOP DO NOT TIGHTEN BOLTS UNTIL STEP 22

15 Unmount the Left-hand squeeze lockbox. Set aside.

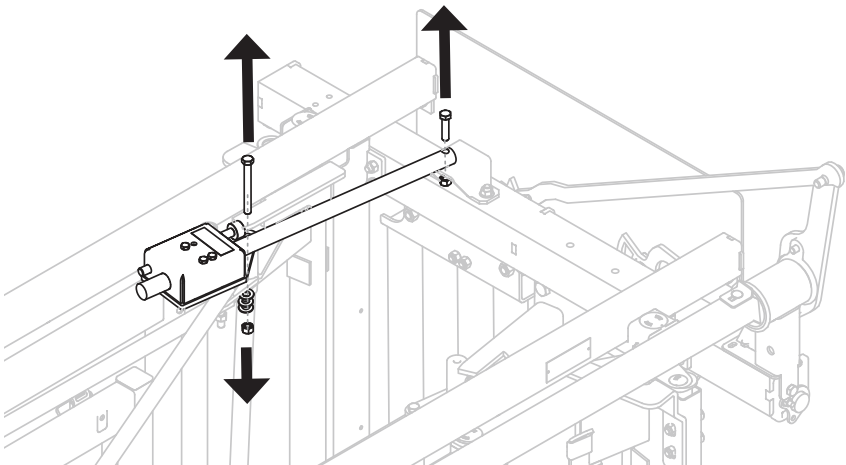

16 Detach the squeeze bracket.

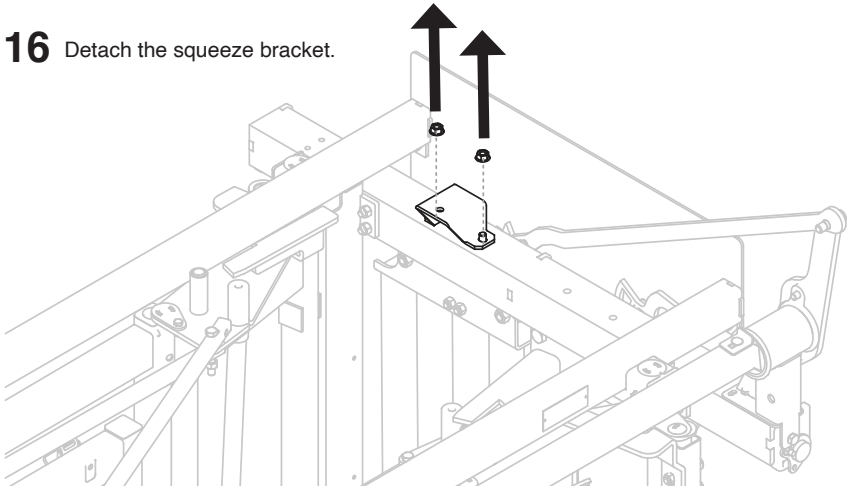

17 Transfer the squeeze bracket to the opposite side.

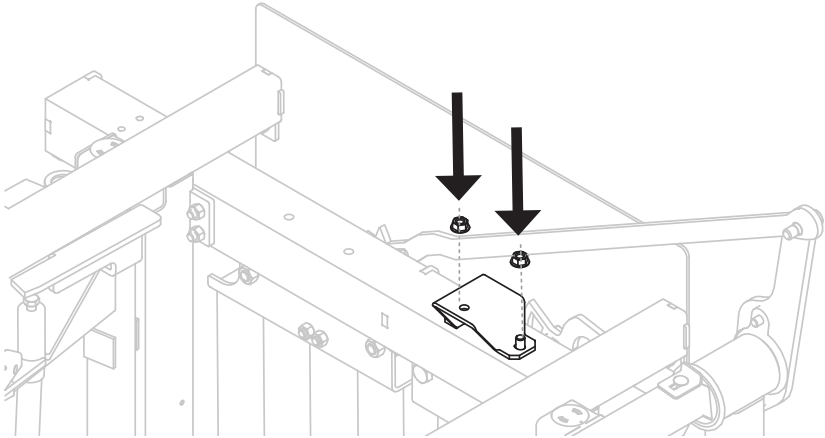

18 Mount the Right-hand squeeze lockbox.

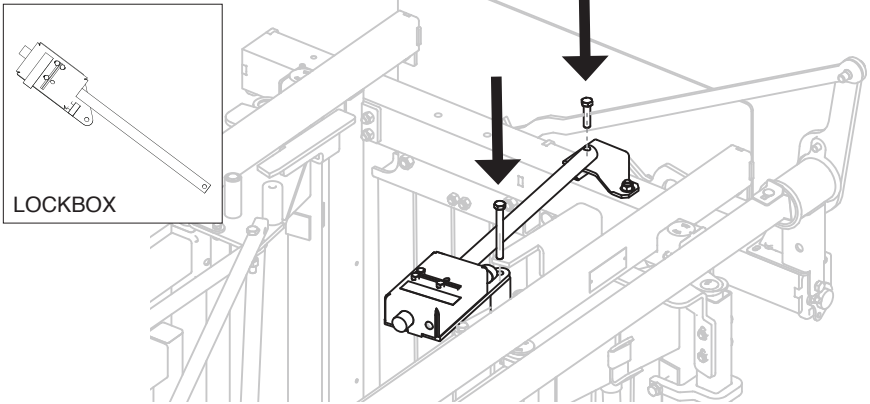

19 Detach the middle tie rod.

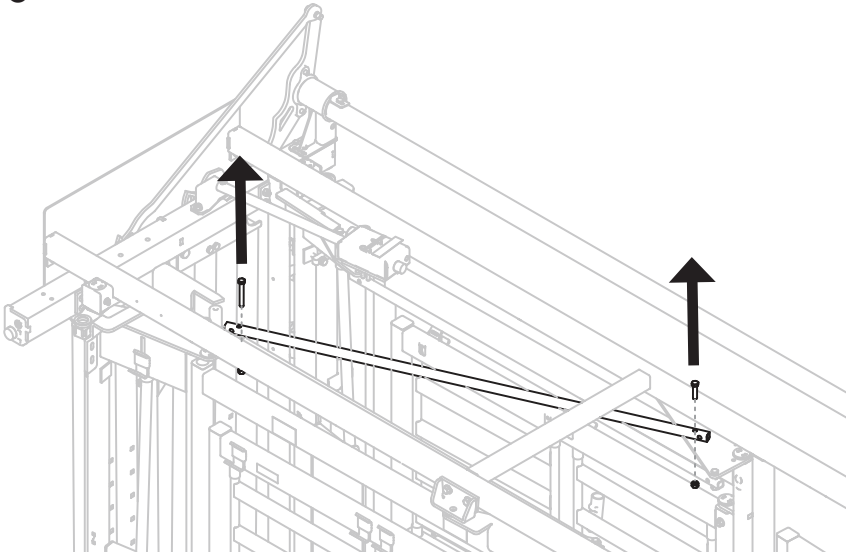

20 Remove bolt from A and transfer to B as shown.

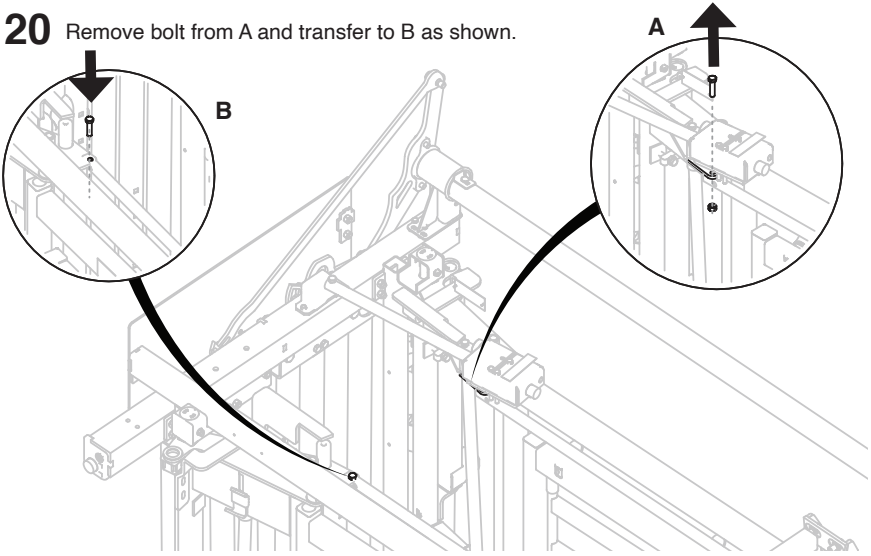

21 Attach the middle tie rod as shown.

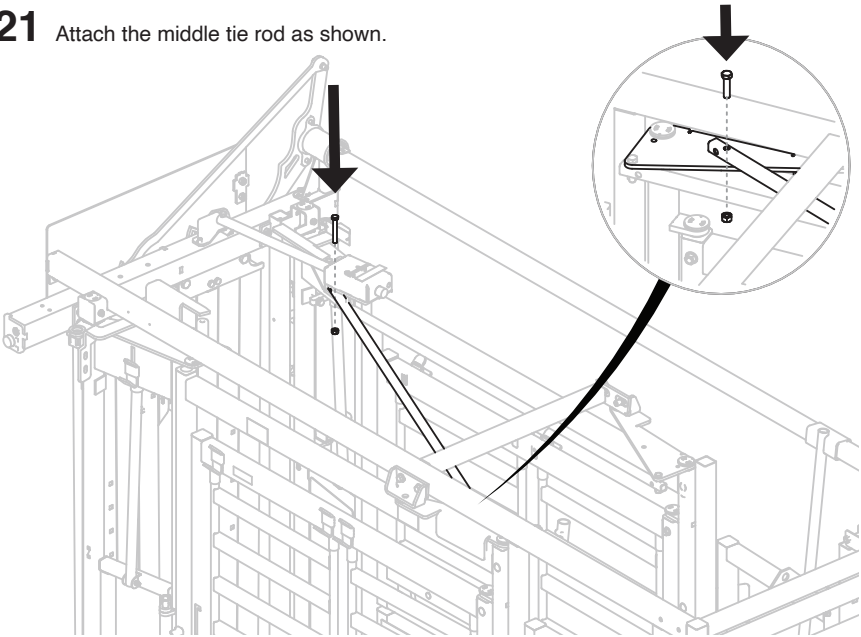

22 Secure bolts on the squeeze bracket and fandangle.

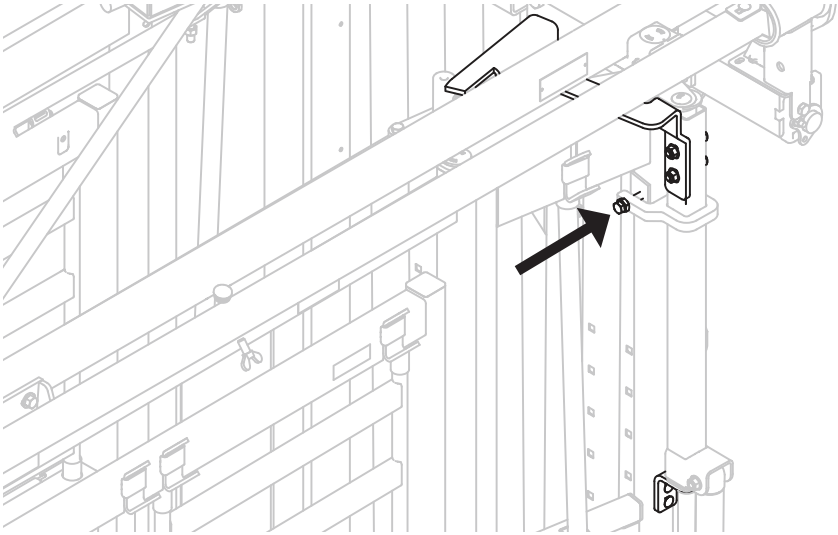

STOP

BEFORE WORKING WITH ANIMALS, SAFETY CHECK:

- ✓ All parts have been reinstalled correctly
- ✓ All chute functions, including the head gate and squeeze mechanisms, are working properly.

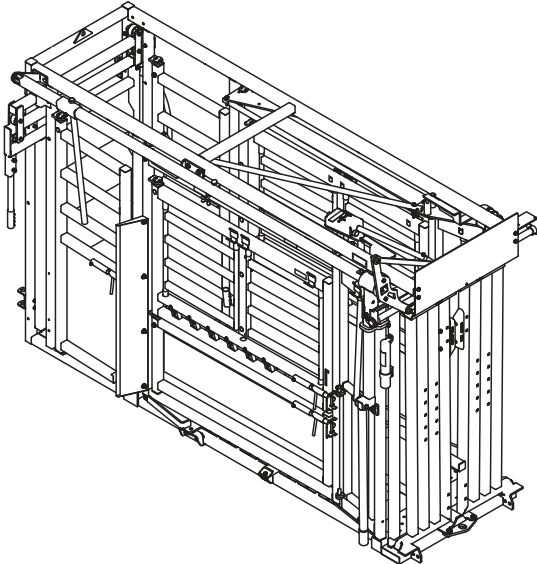

ROLLING DOOR SWITCH

Required Tools:

- 9/16" wrench
- 3/4" wrench

LEFT-HAND TO RIGHT-HAND

Switching from Left-hand to Right-hand operation shown. For Right-hand to Left-hand operation, complete the steps from the opposite side.

Variation with 4 screws on each plate shown. Same steps apply for rolling doors with 2 screws on each plate.

- 1** Remove rolling door handle slider.

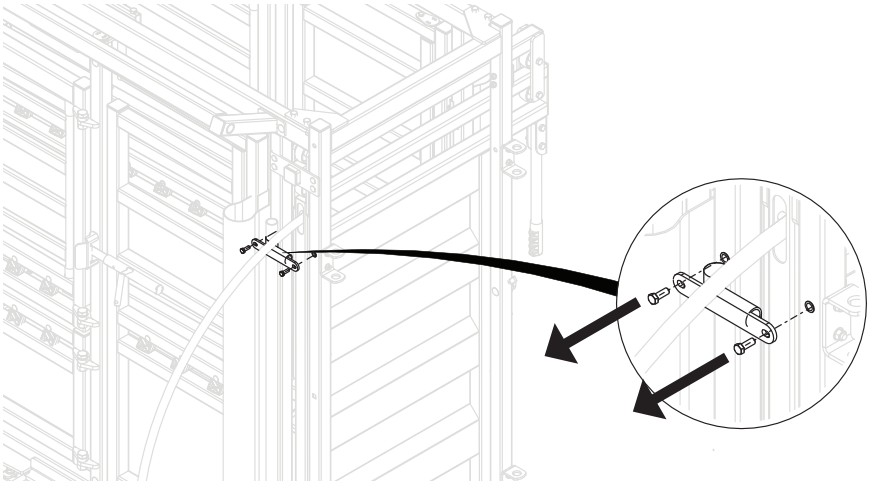

- 2** Remove the rolling door from the main frame.

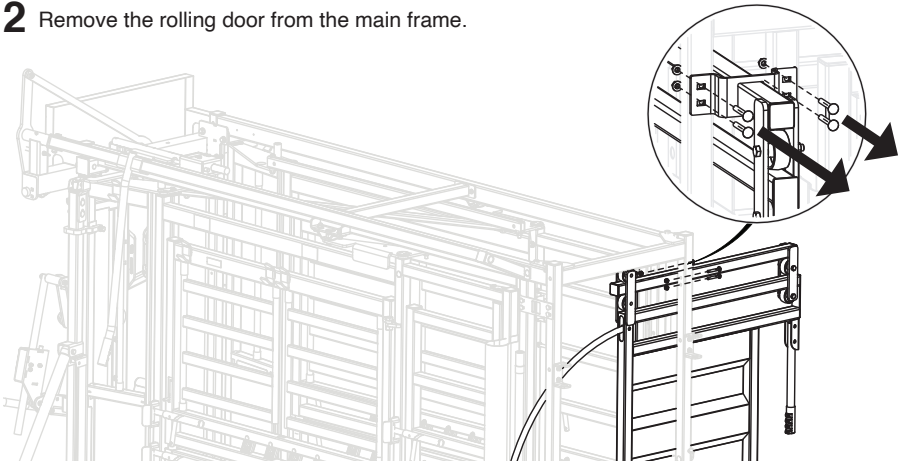

3 Remove the rolling door track plate, and switch to the opposite side.

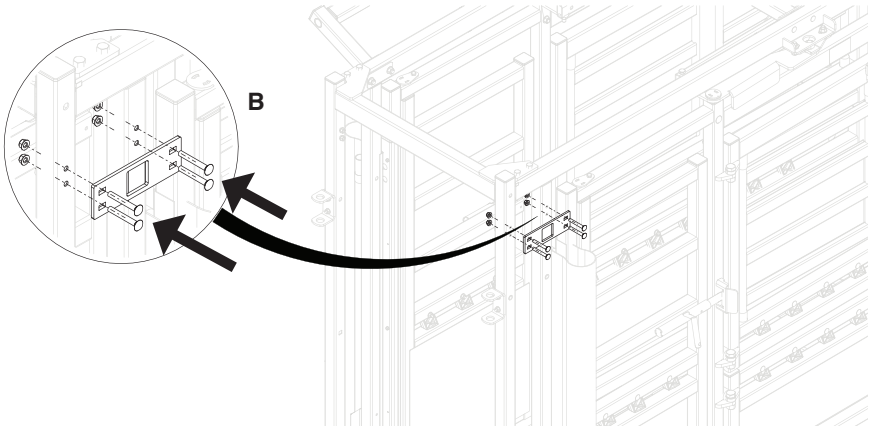
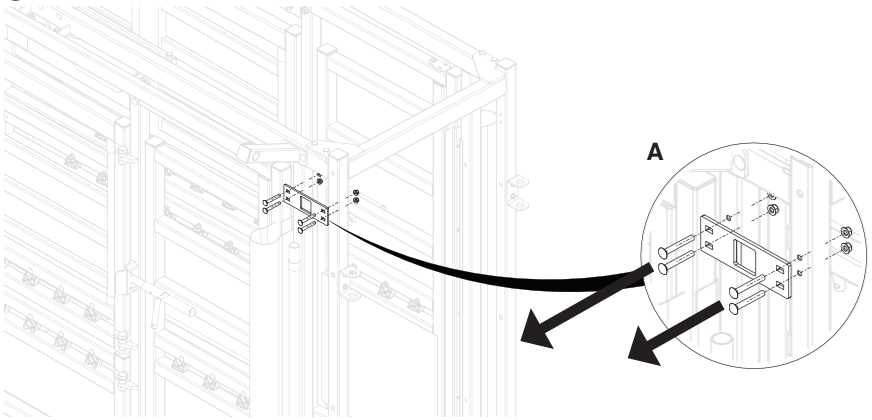

4 Remove the rolling door bumpers and move to the opposite side

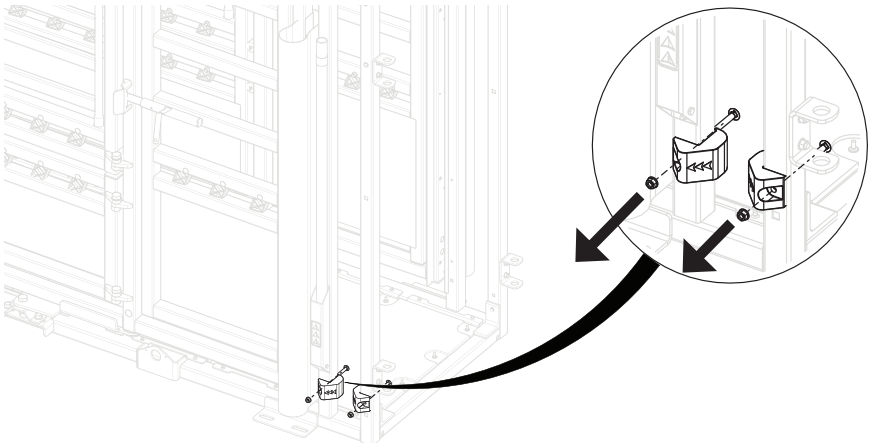

5 Install the rolling door and secure to the main frame.

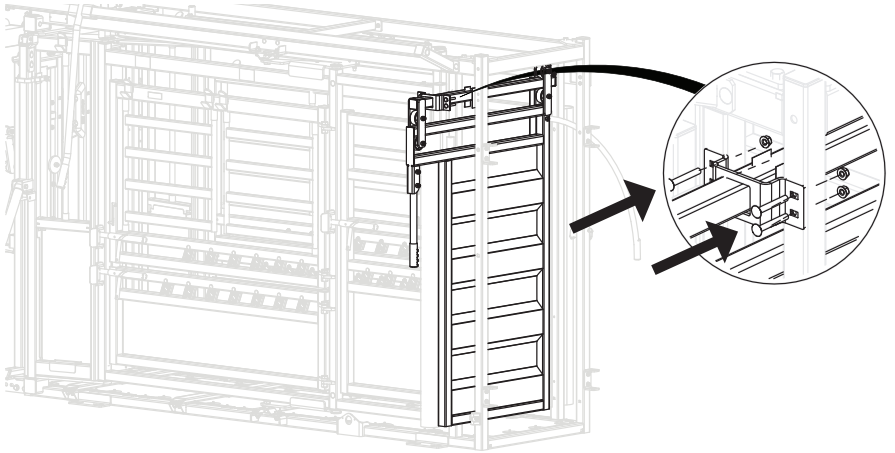

6 Install the rolling door handle slider on the right-hand side.

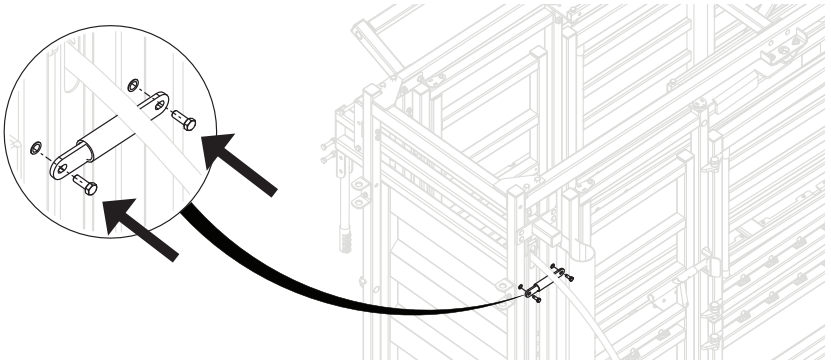

7 Remove the rolling door lock and move to the opposite side.

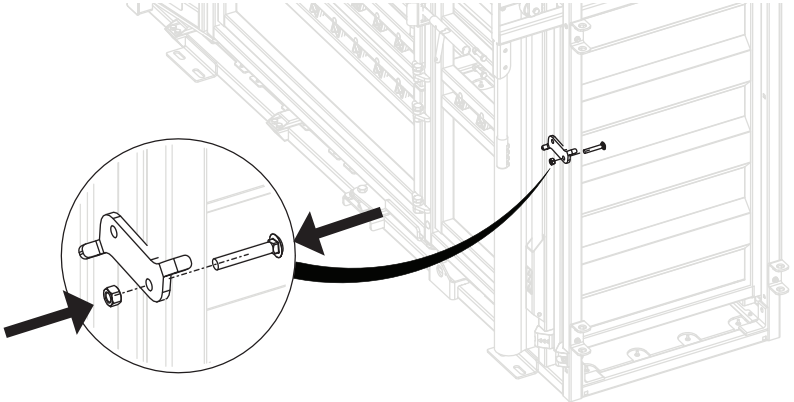

RECOMMENDED MAINTENANCE

All Arrowquip Products are made with precision parts to require minimal maintenance. However, regular maintenance will keep your equipment running smoothly and safely.

REGULAR MAINTENANCE (EVERY 6 MONTHS)

- ✓ **Inspect the entire unit.** Ensure all moving components are free of debris and functioning properly. Use proper cleaning and troubleshooting steps, if necessary.
- ✓ Lubricate slam latches and door hinges with WD-40 Dry Lube.

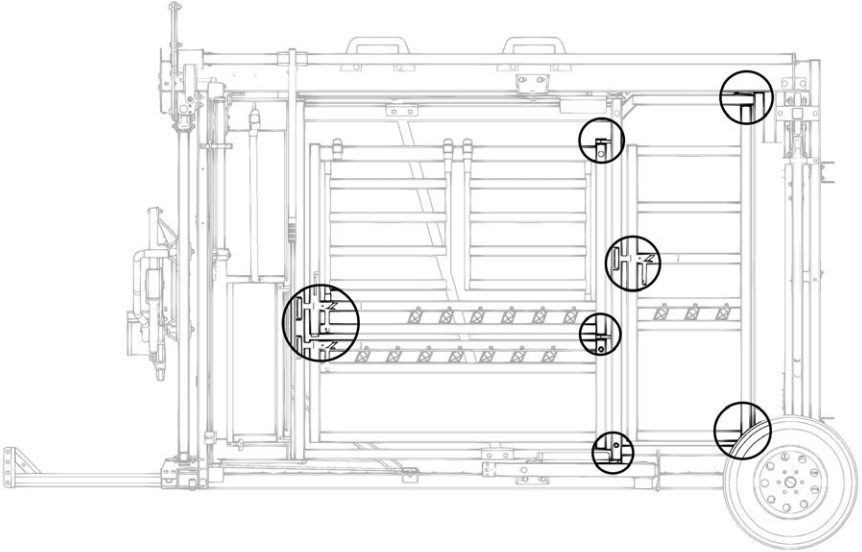

- ✓ Check gate latches and striker plates for wear. Ensure gates are locking securely.
- ✓ Inspect the head gate.
 - a. Bolts on the head gate hammers should be tensioned correctly. There should be enough play for the hammers to move freely in their slots.

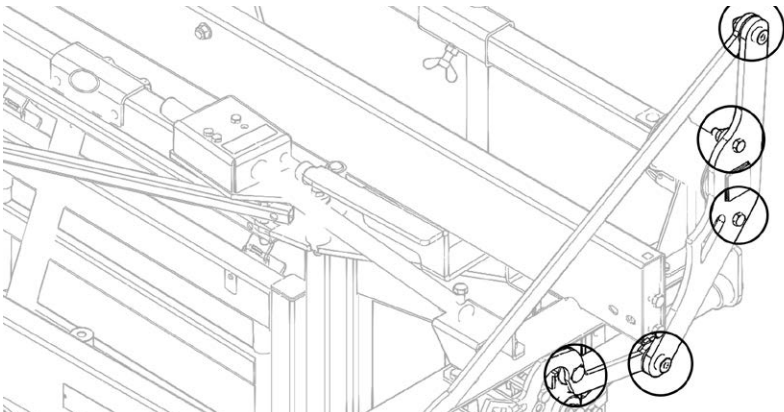

- b. You should feel the head gate rollers moving when you open the head gate. The rollers should be tight enough to be moved by hand, but not over-tight to cause the rollers to bind.

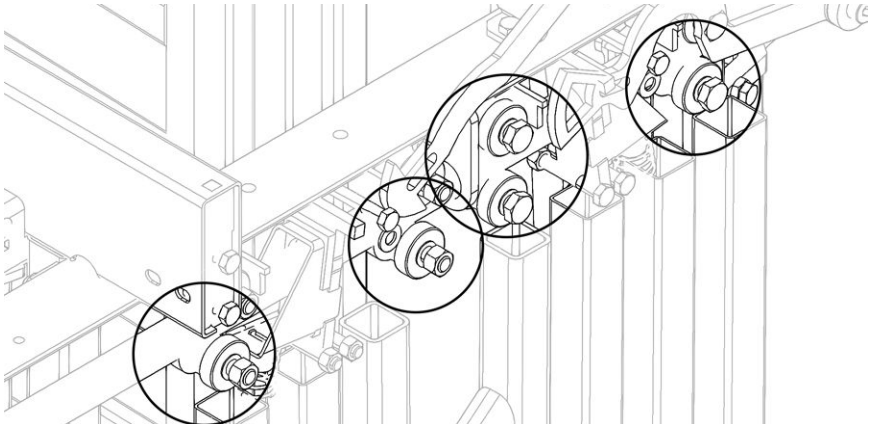

- ✓ Clean bottom head gate door track to prevent dirt-build-up.

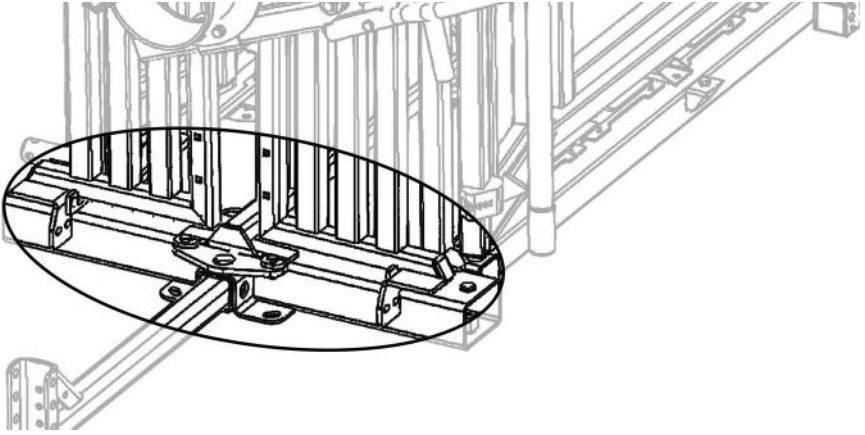

- ✓ Clean the chute floor. Excess build-up of manure or dirt inside chute can cause the squeeze and head gate to malfunction.
- ✓ Check main squeeze pivot bolt for wear.

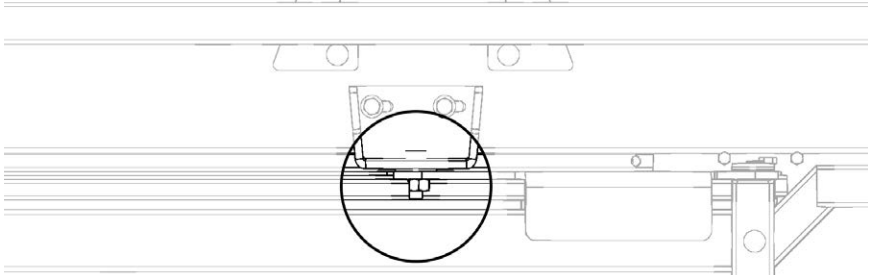

WHEN NECESSARY

- ✓ Clean the unit to remove excess build-up or dirt.
- ✓ If needed, clean and lubricate locking mechanisms: Q-Catch track shaft, squeeze lockbox, and head holder (if applicable)

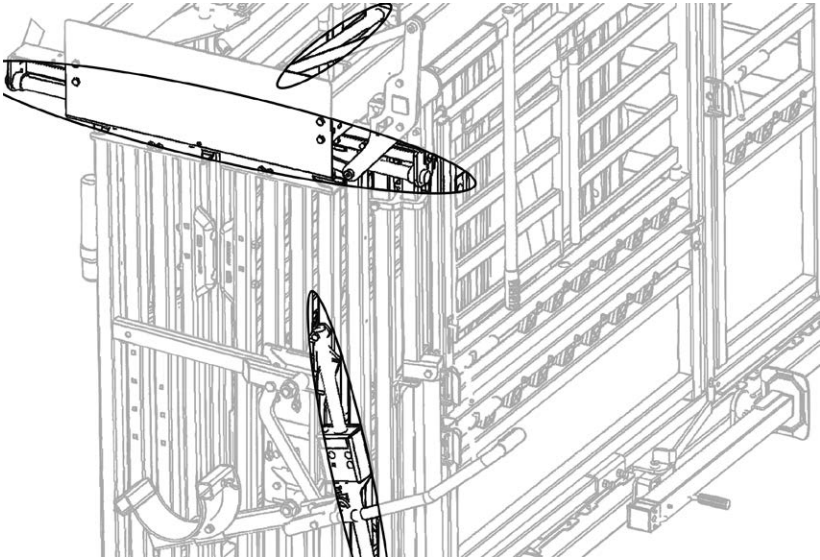

- a. To clean: Use brake cleaner to remove build-up and degrease the shaft. Open and close (or squeeze and un-squeeze) to clean the entire shaft.
 - b. To lubricate: Spray WD-40 Dry Lube on a rag. Open or squeeze. Wipe shaft. Close or un-squeeze. Wipe shaft. Open and close (or squeeze and un-squeeze) a few times to work the lubricant in.
- ✓ Adjust the squeeze lock settings.
 - a. Loosen jam nuts, and back out front and rear bolts.

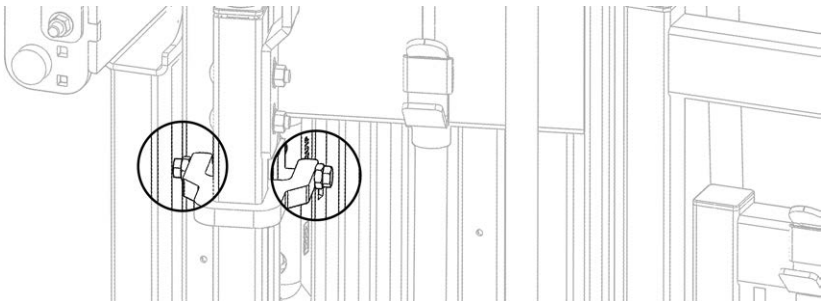

- b. Squeeze the chute to get a visual of the release pin.
- c. Apply inward pressure on the squeeze handle. Adjust rear bolt until there is 1/4" – 3/8" gap between the fandangle and release pin.

- d. Apply outward pressure on the squeeze handle. Tighten the front bolt until there is clearance between locking collar and box.
- e. Re-tighten jam nuts.
 - Tightening = less push
 - Loosening = more push
 - You will not have to push the release pin very far to enable release.

The sole purpose of the Release Pin Collar (if applicable) is to stop the release pin from going in too far, and re-locking the shaft.

TROUBLESHOOTING GUIDE

If you have a problem with your Q-Catch squeeze chute, please consider the following tips or call us at 1-877-275-6075.

1. Make sure the unit is situated on level ground or base.
2. If head gate has minimal use over extended periods, this may cause head gate doors to become stiff to operate and/or difficult to release. This can be easily fixed by lubrication of the rollers and the Q-Catch track shaft with WD-40 Dry Lube.
 - a. To lubricate the Q-Catch track shaft, wipe shaft with a rag sprayed with WD-40 Dry Lube. Repeat with head gate doors closed and open to properly lubricate the entire shaft.
 - b. Open and close the head gate a few times to work the lubricant in.
3. Make sure head gate door tracks are free of debris.
4. Keep floor clean. Excess build-up of manure or dirt inside chute can cause the squeeze and head gate to malfunction.
5. Ensure bolts on the head gate are tightened correctly.
 - a. Too tight will cause the locking and releasing of head gate doors to malfunction.
 - b. Too loose will cause premature wear on head gate parts.
 - c. On the head gate, there is a short hammer and a long hammer between the handle pivot and doors. These two hammers have a slot in them – check that there is free movement for the bolt to move the entire length of this slot, and the lock nuts are correctly tightened.
 - d. The door hammers also contact the release pins on the lock plates when the head gate handle is pulled back. Ensure there is an air gap between levers and release pins when head gate is being pushed or in an idle position.
6. Check nuts and bolts on items and ensure that they are tightened correctly, and are not binding.
7. All lock boxes and pivot points should be lubricated as needed with WD-40 Dry Lube.

RECOMMENDED USE

3500 head of cattle per year.

Follow the recommended use instructions to maximize the lifespan of your equipment. Arrowquip products that have only been used within acceptable tolerance following the stated recommended use will be eligible to claim warranty.

WARRANTY

Your product must be registered to claim warranty, and to ensure that Arrowquip has the required information to contact you in the event of a product or part recall. Any owner who fails to register their product warranty with Arrowquip through their Authorized Arrowquip Dealer voluntarily voids their warranty. Arrowquip will repair or replace products or parts of a product that prove defective due to manufacturer defect during the Warranty Period, at their sole discretion. This excludes defects resulting from normal wear and tear or product misuse. NOTE: Any modification, in any fashion, to any Arrowquip equipment immediately voids the product warranty. This includes the parts contained therein.

Eg. If a modification is made to the squeeze mechanism in a squeeze chute, and the sternum bar is bent afterwards, warranty for the damaged part, the sternum bar, contained in the modified equipment, the squeeze chute, is void. In addition, any remaining warranty for the squeeze chute and other parts contained therein, including, but not limited to, the head gate, locking system, Q-Catch system, and rollers, is null and void.

REGISTER FOR WARRANTY NOW:

Online: arrowquip.com/product-registration

Phone: 1-877-275-6075 | **Email:** cs@arrowquip.com

ADD-ONS MAINTENANCE & SAFETY PRECAUTIONS

MANUAL HEAD RESTRAINT: 3rd GENERATION Q-CATCH HEAD HOLDER / CHIN BAR

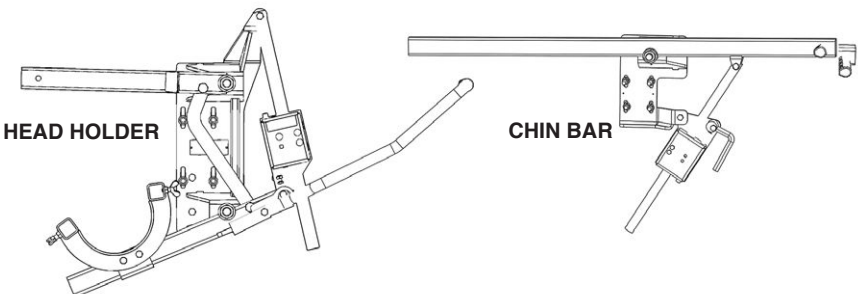

For complete information, read the Head Restraint manual.

Requirements:

- 2 people
- 3/4" wrench

Installation:

3rd Generation Head Holder shown in images. Same instructions apply for the chin bar.

1 Align the head holder or chin bar to the slots in the head gate according to your desired height.

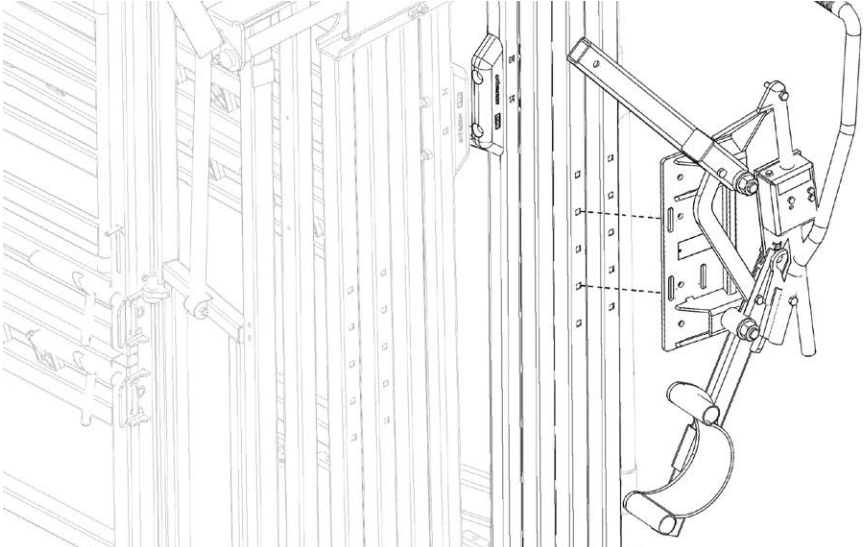

2 Secure the head holder with 4 bolts.

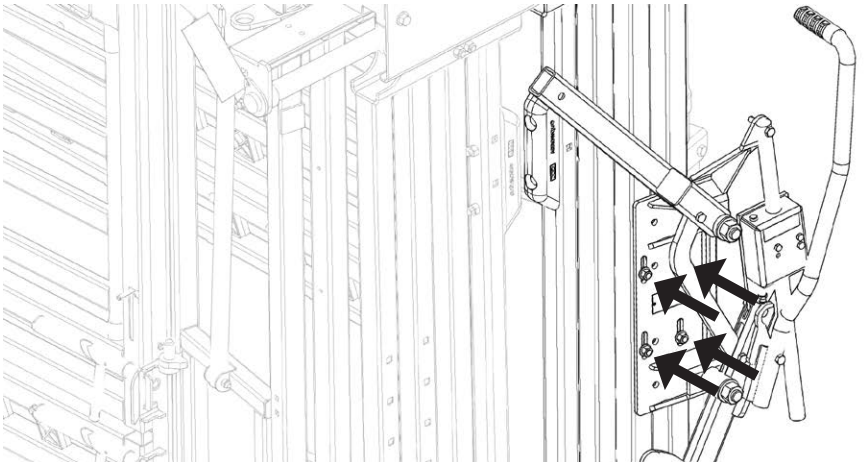

Safety Precautions:

1. Ensure that the head holder remains open until required to hold the animal's head.

Maintenance:

1. Add grease through the grease nipples **as needed**.
2. Every 6 months:
 - a. Check bolts to ensure they are tightened properly.
 - b. Spray brake cleaner on a rag and wipe the lockbox shaft while opening and closing the head holder.

SHEETED STERNUM BAR

Installation:

- 1** Insert the sternum bar into the bracket.

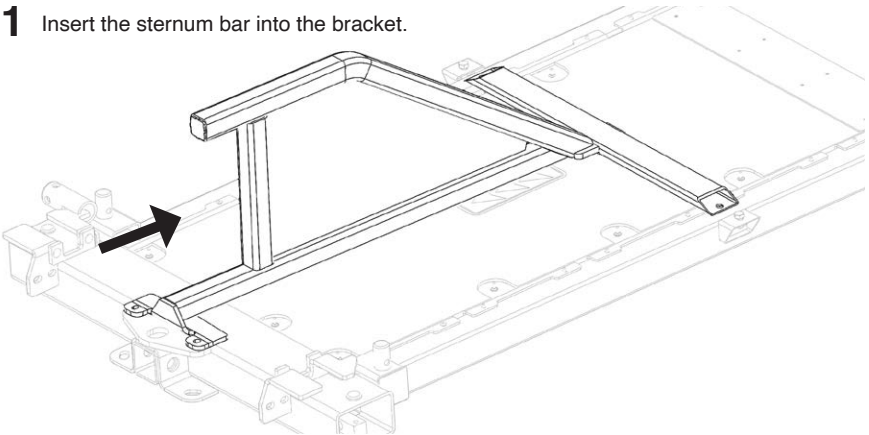

- 2** Fasten bolts to front plate.

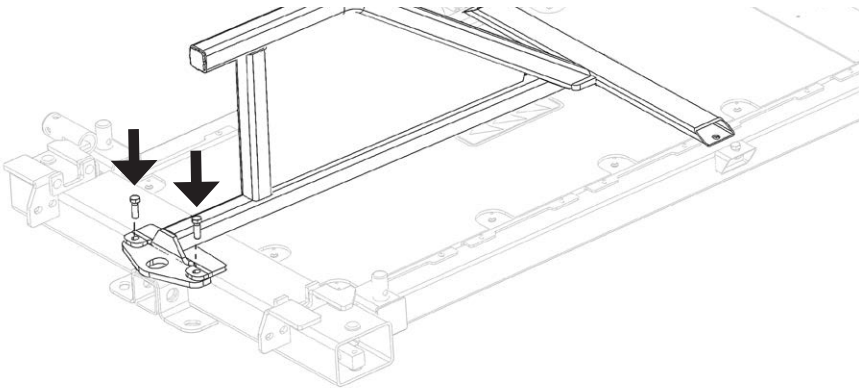



SAFETY CHECK:

- ✓ Ensure that the sternum bar is installed correctly before running cattle through the chute.

Safety Precautions:

1. Remove the sternum bar when working calves.

TRIMMING BAR

Installation:

- 1 Place both brackets on the chute.

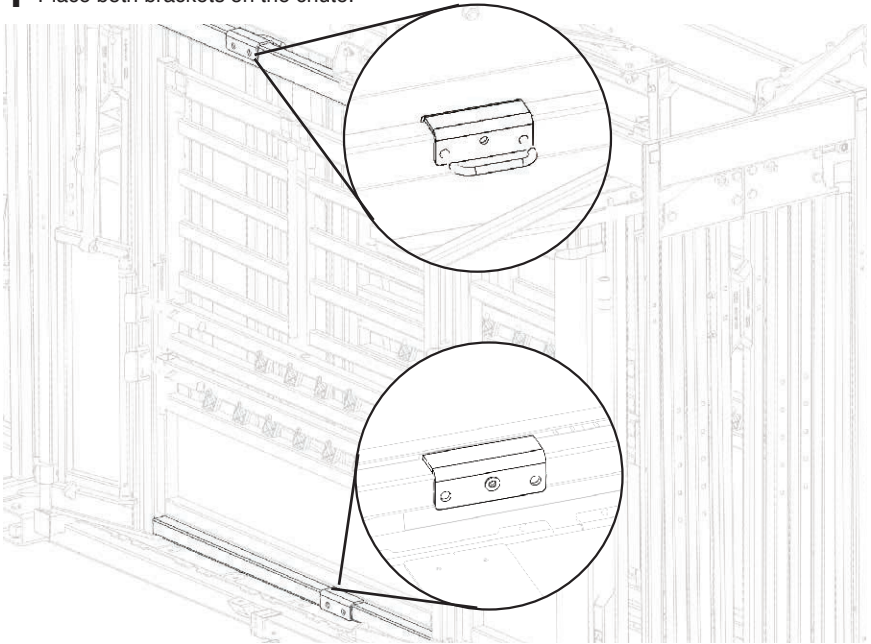

2 Attach the trimming bar to the bottom bracket.

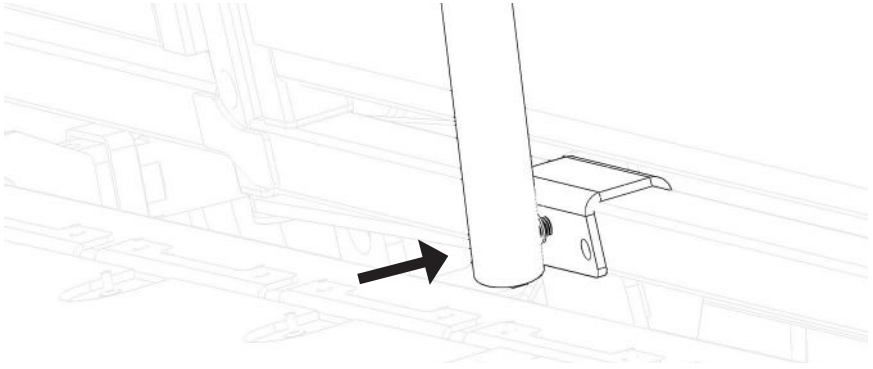

3 Insert the trimming bar into the top bracket.

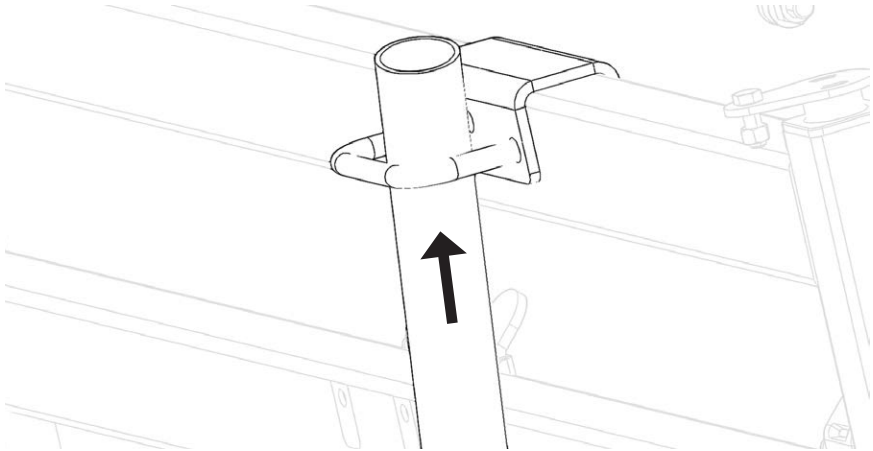

4 Adjust trimming bar position to your preference. Tighten bolts to secure.

Safety Precautions:

1. Ensure the trimming bar is installed and secured correctly before running cattle through the chute.

WHEEL KIT

Requirements:

- 2 people
- Wheel kit

Jack Reference:



Installation:



THE CHUTE MUST BE FLAT ON THE GROUND BEFORE PROCEEDING.

1 Install both jacks on the mounts located near the vet cage.

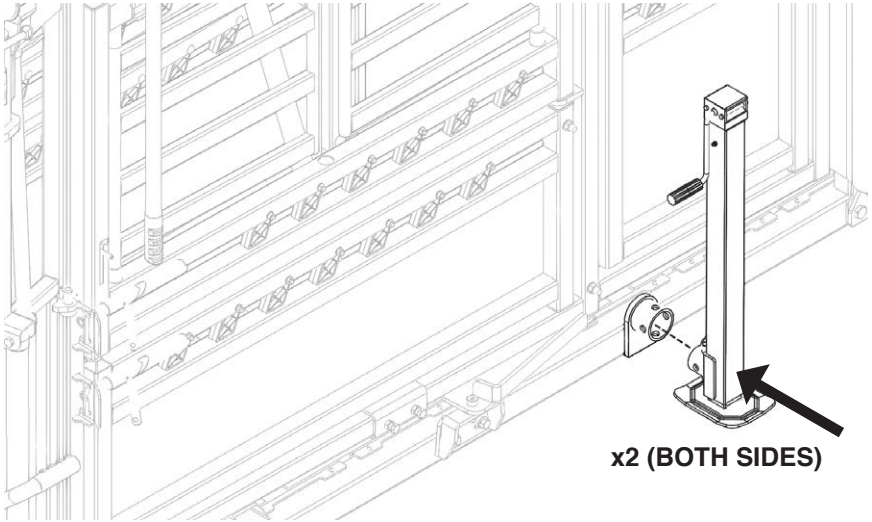

2 Using both jacks simultaneously, raise the chute 12" above the ground.

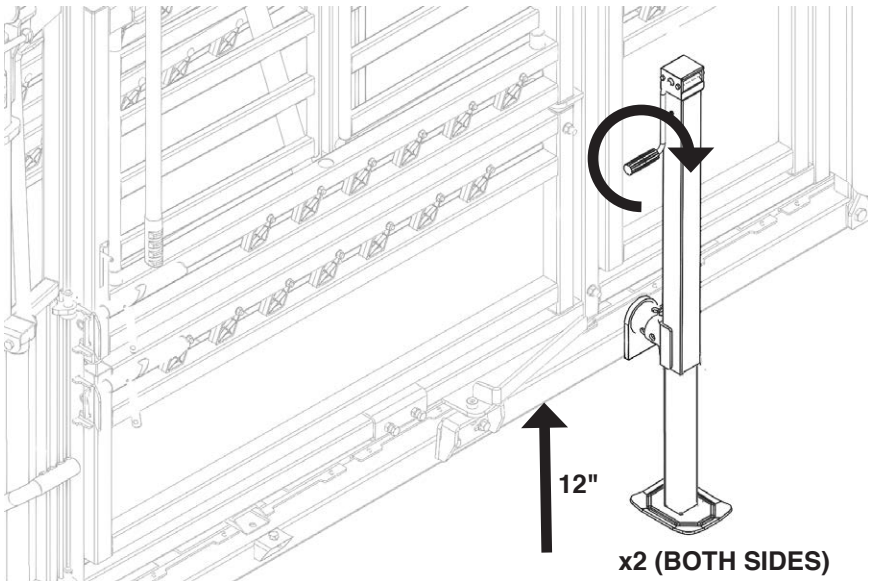

3 Install wheels and secure with transport pins.

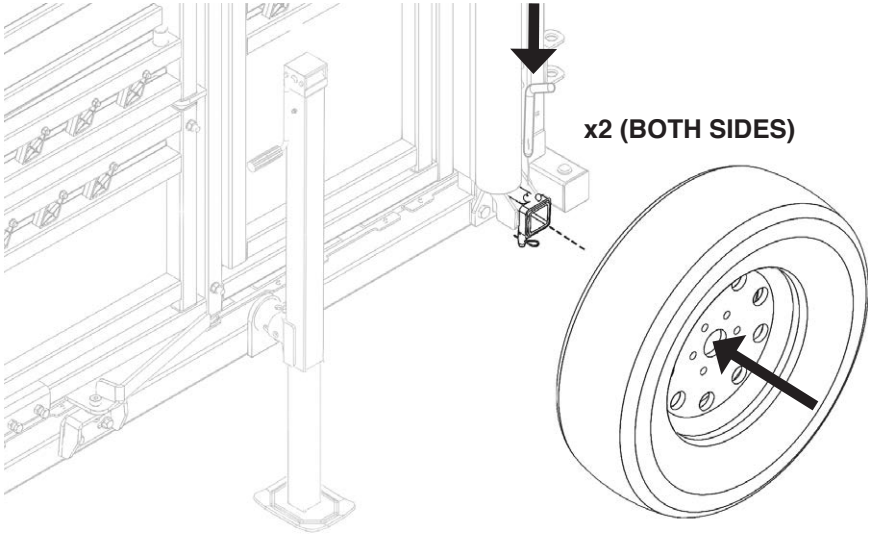

4 Remove both jacks.

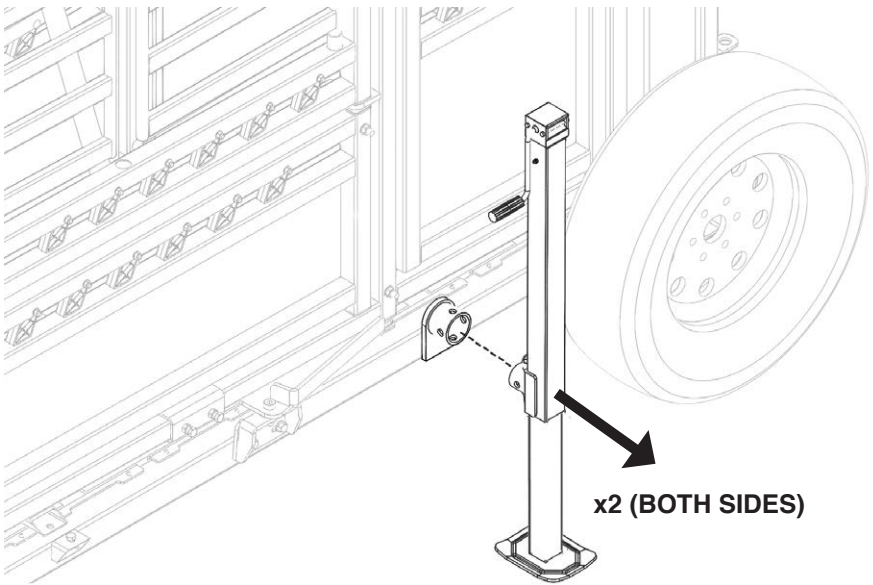

5 Attach the removable jack mount to the front of the chute and secure with the pin.

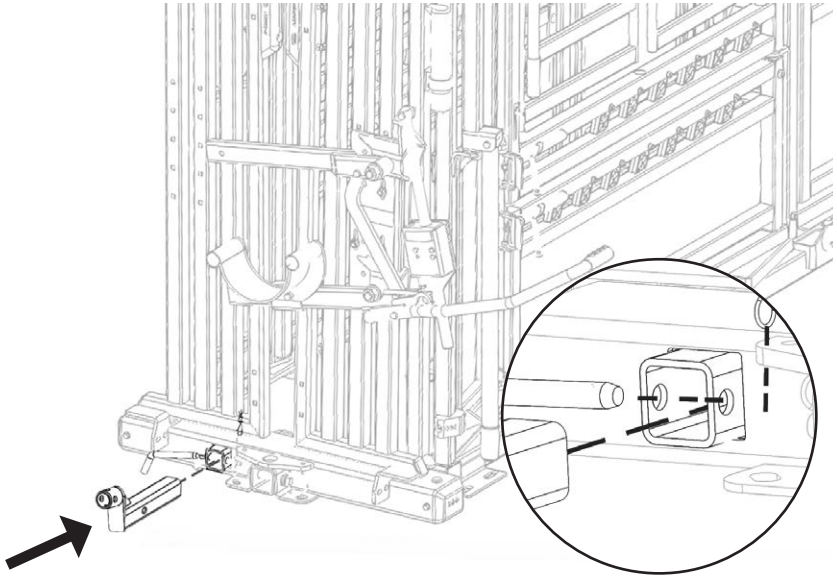

6 Mount the jack to the front of the chute.

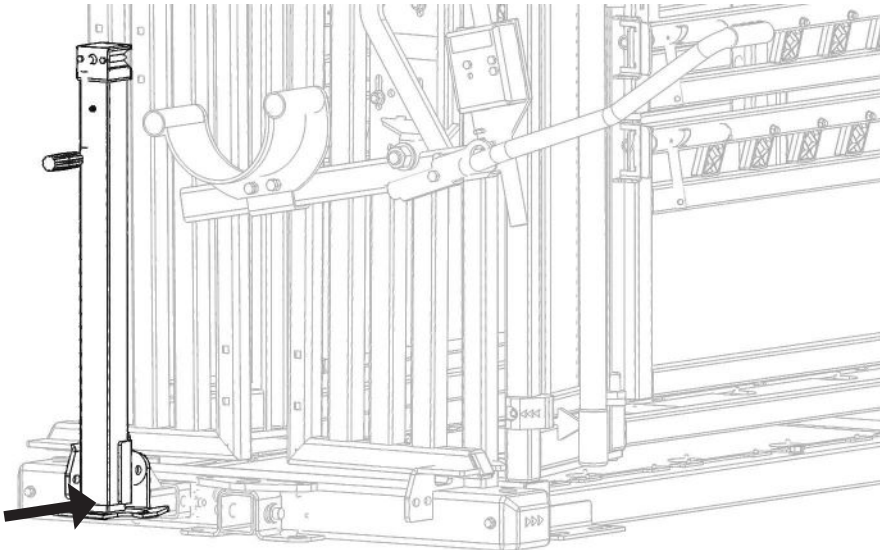

7 Using the front jack, raise the chute 3" above the ground.

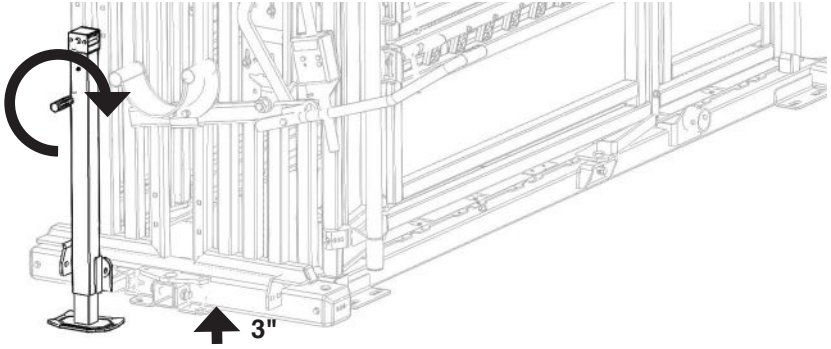

8 Install the hitch and secure with the pin.

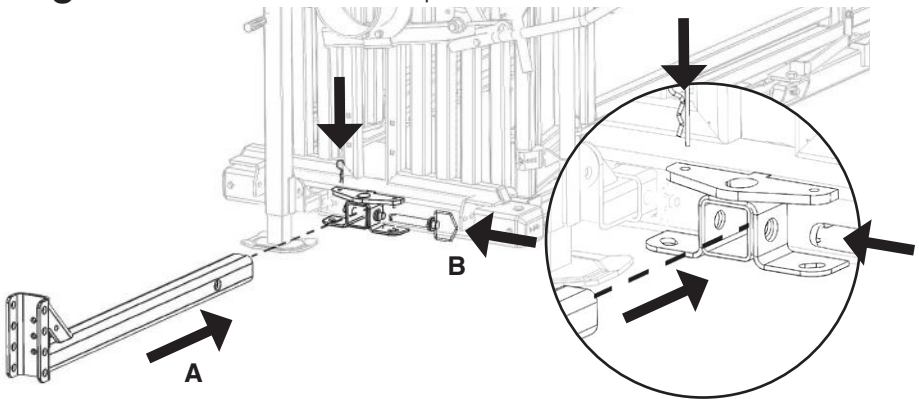

9 Attach the unit to the towing vehicle. Adjust the hitch to the proper position for the vehicle, if necessary.

10 Retract the front jack completely.

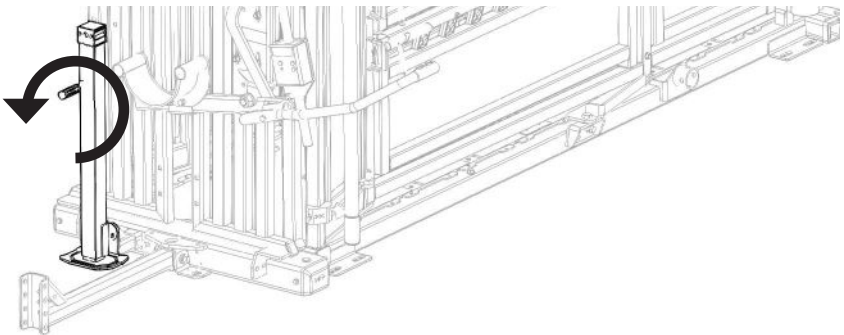

STOP

SAFETY CHECK:

- ✓ Jacks are retracted completely.
- ✓ All doors and gates are shut.
- ✓ Tires are in good condition.

Removal:

- 1** Lower the front jack to the ground and unhook the unit from the towing vehicle.

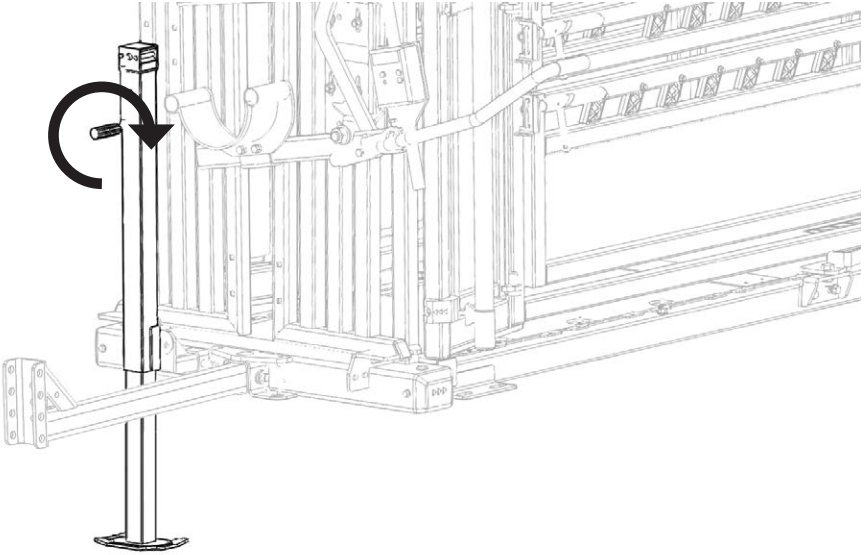

- 2** Remove the hitch.

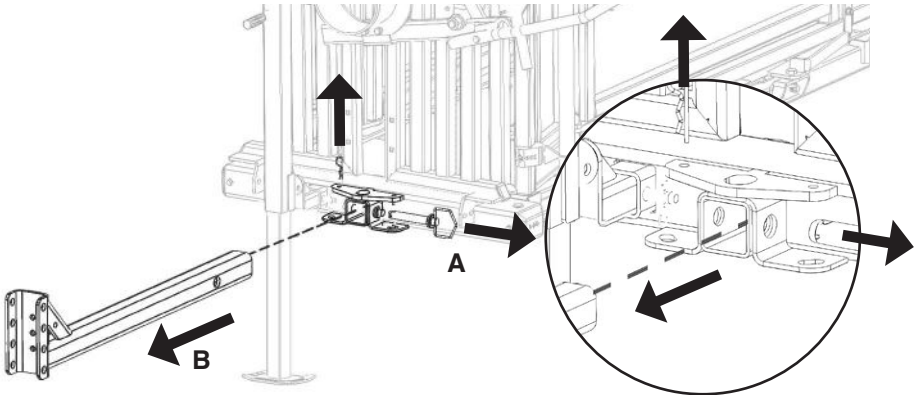

- 3** Using the front jack, lower the chute to the ground.

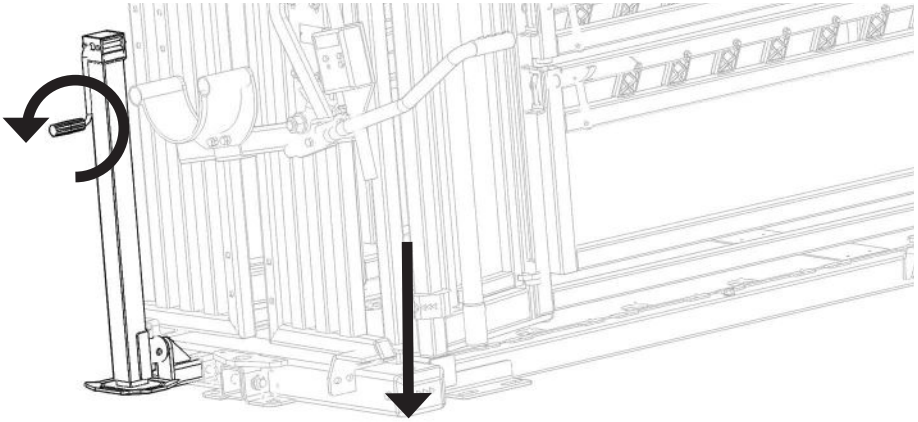

STOP

THE FRONT SECTION OF THE CHUTE MUST BE LYING FLAT ON THE GROUND BEFORE PROCEEDING.

- 4** Transfer the front jack to the rear mount. Attach the second jack to the opposite side.

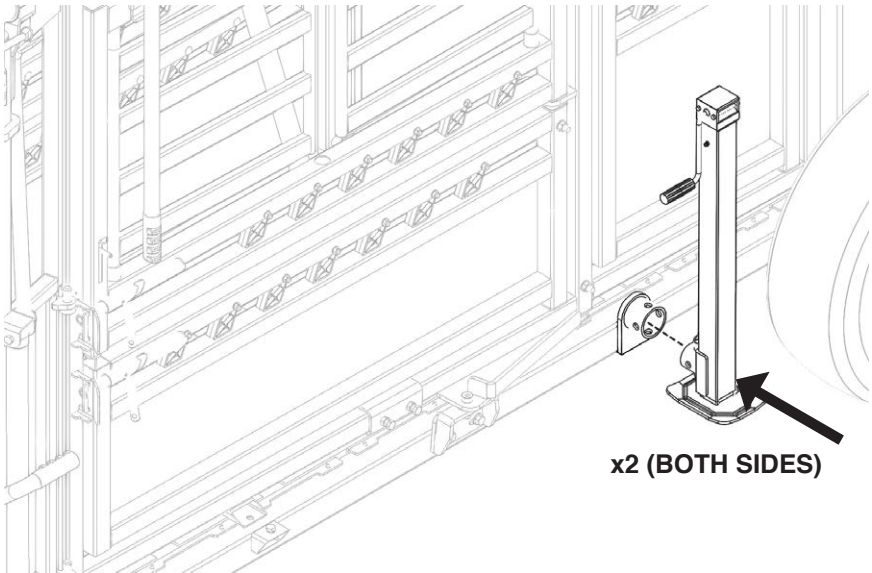

- 5** Using both jacks simultaneously, raise the chute until the tires are 1" above the ground. Remove tires and set aside.

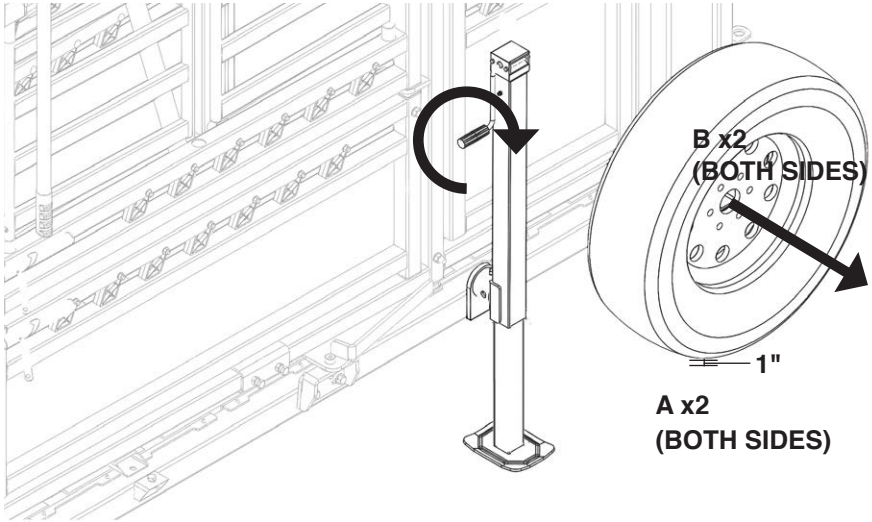

- 6** Using both jacks simultaneously, lower the chute until it is lying flat on the ground.

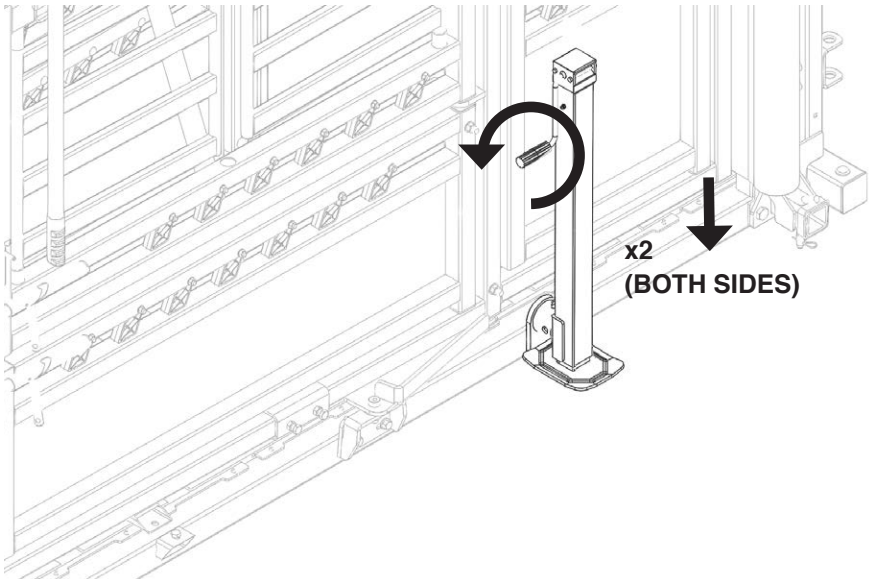

7 Remove jacks and set aside.

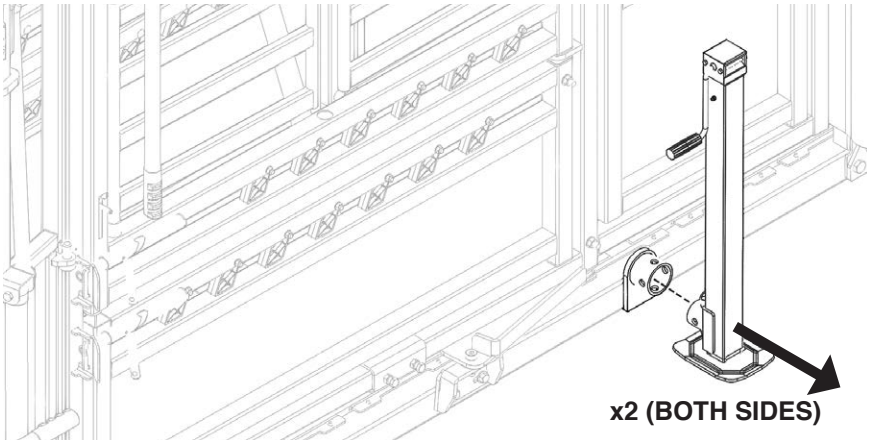

STOP

SAFETY CHECK:

- ✓ Inspect for damages due to transport
- ✓ Head gate and squeeze mechanisms are functioning properly
- ✓ All latches on doors, gates, and panels are functioning properly
- ✓ When applicable, all add-ons are properly installed and functioning

WHEEL MAINTENANCE

It is extremely important to apply and maintain proper wheel mounting torque on your trailer wheel. Torque is a measure of the amount of tightening applied to a fastener (nut or bolt) and is expressed as length force. For example, a force of 90 pounds applied at the end of a wrench on foot long will yield 90 ft. lbs. of torque. A torque wrench is the best method to assure the proper amount of torque is being applied to a fastener.

Be sure to use only fasteners matched to the cone angle of your wheel – usually 60° or 90°. The proper procedure for attaching your wheels is as follows:

1. Start all bolts or nuts by hand to prevent cross-threading.
2. Tighten bolts or nuts in the sequence shown for wheel torque requirements.
3. The tightening of the fasteners should be done in stages. Following the recommended sequence, tighten fasteners per wheel torque requirements diagram.
4. Wheel nuts/bolts should be torqued before first road use and after each wheel removal. Check and re-torque after the first 10 miles, 25 miles, and again at 50 miles. Check periodically thereafter.

Maximum torque level that can be safely applied to the studs are: Stud Size: .5"-20 UNF, class 2A Maximum Torque: 120ft. lbs.



ARROWQUIP

If you have any questions regarding your product or require assistance, please contact Arrowquip's Client Care Team at 1-877-275-6075 or by email at cs@arrowquip.com.